

For many years the lock-in amplifier was an all-analog instrument. As technology developed, digital electronics, in the form of microprocessor control, was introduced, although initially only in a supporting role. Later, the output filters were implemented using digital techniques, but the phase-sensitive detector (PSD), or demodulator, continued to use analog circuitry. In recent years instruments using Digital Signal Processing (DSP) techniques have been introduced and in these even the PSD is fully digital.

This Technical Note describes the technology used in those **SIGNAL RECOVERY** lock-in amplifiers which employ analog detection, such as the models 5109, 5110, 5209, 5210 and the model 5302 (when it is operating above 20 Hz). Technical Note TN1003 provides similar information for the DSP instruments.

Introduction

Lock-in amplifiers which use an analog signal processing channel are invariably known as analog instruments, even if they include digital output filters. The term “digital lock-in amplifier” usually refers to units which utilize a DSP demodulator.

DSP instruments will generally give better performance than their analog counterparts and have inevitably become the first choice for the user. It is worth remembering, however, that there are still some applications for which the analog instruments will offer distinct advantages. Three important examples are:-

- ◆ Improved performance when used as the first lock-in amplifier in a “dual demodulation” experiment. In this application, a high frequency “carrier” signal is amplitude modulated at another, lower, frequency. The overall signal is detected by a lock-in amplifier which must offer short output time constants to allow the modulation frequency to pass to the output. This is then detected by either a second lock-in amplifier or other instrument, such as a spectrum analyzer. A DSP based lock-in amplifier samples the input signal at a fixed rate, which is typically a few hundred kilohertz, so that as the reference frequency is increased towards this region, there are fewer samples per cycle from which to derive the output. The effect is particularly apparent at short time constants. Hence in these applications, analog units are usually better.
- ◆ Analog instruments provide true analog output filtering and output signals. These features are required for unconditional loop stability when the lock-in amplifier is used as a phase-sensitive detector within a feedback loop. For example, in scanning probe measurements, the probe is vibrated and the lock-in amplifier measures a signal generated as a result of this vibration. The output from the lock-in amplifier is used as a feedback signal to

maintain the mean position of the probe at a constant level above the sample surface. Analog instruments usually perform better in this role.

- ◆ Higher operating frequencies. DSP units are currently restricted to operation at 2 MHz or below, whereas analog units can operate to many megahertz. Although there is a commercially available instrument described as a high frequency DSP lock-in amplifier, it is in fact an analog unit used as a “down converter” followed by a low frequency DSP final detector stage.

Instrument Description

Figure 1 shows the functional block diagram of a typical high performance, analog lock-in amplifier, such as the **SIGNAL RECOVERY** models 5109, 5110, 5209 and 5210. Dual phase instruments include all of the sections shown whereas those sections within the dotted line are omitted in single phase units.

Signal Channel

The input stage may be operated in one of three modes:-

Single-ended Voltage Mode

The signal to be measured is applied to one input connector which operates in single-ended mode and directly feeds the voltage input amplifier.

Differential Voltage Mode

Two input connectors are active and the instrument measures the difference in applied voltage between them.

Current Input Mode

A single connector is active which feeds a current-to-voltage converter, the output of which then drives the voltage input amplifier. The current conversion ratio is usually 10^6 V/A or 10^8 V/A, and the overall current sensitivity is given by multiplying this ratio by the full-scale voltage sensitivity setting.

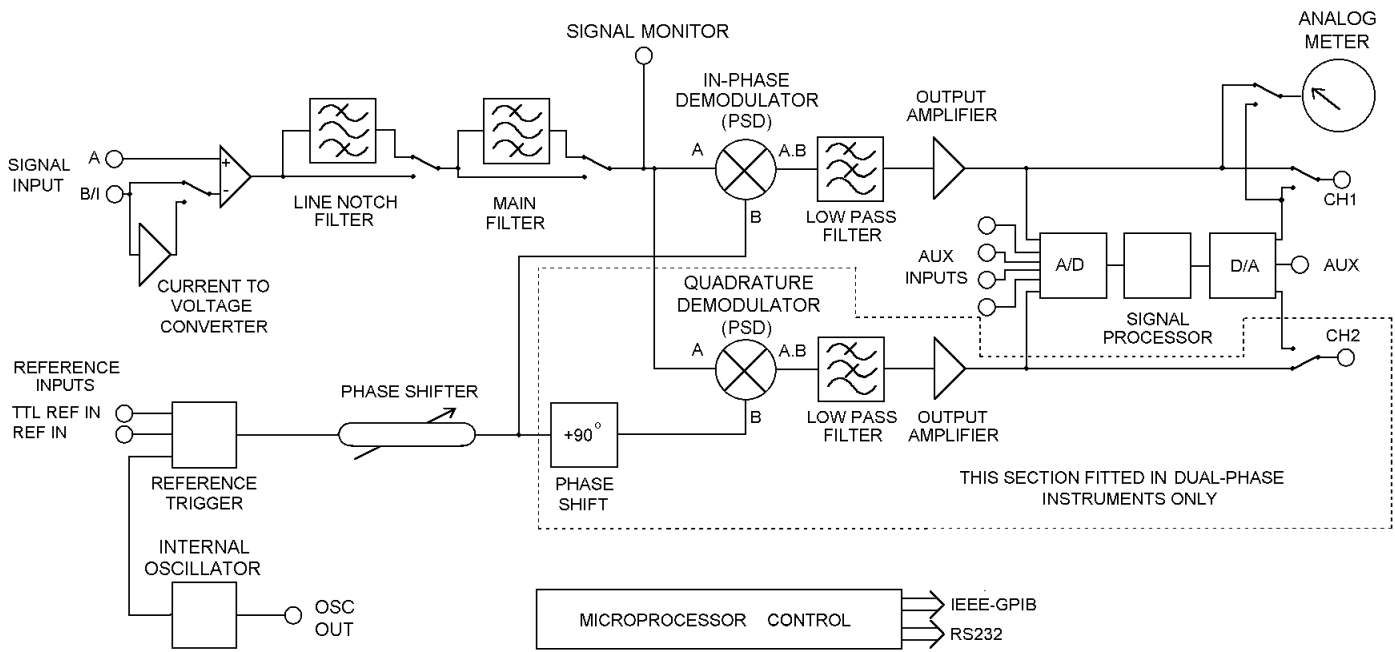

Figure 1

For example, if the voltage sensitivity is set to be 100 mV full-scale and the 10^8 V/A current conversion ratio is selected, then the instrument's full-scale current sensitivity will be 1 nA.

In the current measuring mode, the input impedance is low (typically less than 100 Ω) although it does rise as the operating frequency increases, and is higher for the 10^8 V/A than for the 10^6 V/A conversion setting. If the very best performance is needed then it may be better to use a separate dedicated current preamplifier.

The current input connector is often combined with the "B" voltage-mode input connector to simplify the layout of the front panel.

Line Notch Filter

The output of the input amplifier is optionally passed through a line notch filter. This is a band-rejection stage, designed to remove 50/60 Hz and/or 100/120 Hz interference from the input signal. Since the line frequency can vary by up to $\pm 1\%$ of its nominal value, the Q -factor of the filter is only 1. Any higher value would not give satisfactory attenuation over the range of possible input frequencies. However this low Q value has the disadvantage of introducing significant attenuation and phase-shifts even at frequencies well removed from the set frequency.

Main Filter

Following the line notch filter, the signal passes to the main filter. This may be operated in the low-pass, bandpass or notch mode, or may be bypassed. When the user chooses to make it active, the phase-sensitive detector(s) in the following stage are switched to a special mode so that the instrument provides an overall sinewave, or fundamental, response.

The standard operating condition of the instruments is with the main filter set to the bandpass mode and tuned to the reference

frequency. In this mode the roll-off of the filter both above and below the reference frequency is 12 dB/octave, giving rejection of interfering noise components in both frequency regions.

In many situations, particularly when using low reference frequencies, most of the interfering signals are at frequencies greater than the reference frequency, so that better performance is obtained by using the low-pass mode. In this case, the roll-off of the filter attenuating components above the reference frequency increases to 24 dB/octave.

The flat mode is often used for non-demanding applications and may give the best results when the input signal is a squarewave and the interfering noise is white.

The output from the main filter passes to the phase-sensitive detector(s) where it is multiplied by the output from the reference circuitry. In addition this signal is often brought out to a connector on the front panel of the instrument, allowing the user to monitor the effect of the filters on the input signal before it passes through the demodulator.

Reference Channel

The reference channel takes its input either from the external reference input connector, or from the internal oscillator and generates in-phase (and quadrature in a dual phase lock-in amplifier) switching waveforms which drive the demodulator(s).

Reference Trigger

The reference trigger circuit takes the applied reference signal and uses a threshold detector to produce an internal trigger signal. The only requirement imposed on the reference signal is that it has only two zero crossings per cycle and that it is of sufficient amplitude. This means that square, triangular and other waveforms can be used as well as the more usual sinusoidal form. The presence of the trigger threshold detector

does however give rise to the possibility of phase-shifts at low frequencies, typically below 10 Hz, so the instruments also include a TTL, or logic level, reference input for use at these frequencies.

The reference channel can operate in either the F or 2F mode, which means that the output signal is either at the applied frequency or at twice this frequency. The

SIGNAL RECOVERY model 5302 extends this range by allowing operation up to and including the seventh harmonic.

Phase-Shifter

The output from the trigger circuit is applied to a phase-shifting circuit, which allows the user to ensure that the phase difference between the signals at the reference and signal channel inputs to the in-phase demodulator is zero. Generally this phase-shifter may be set in increments of a few tens of a millidegree and it usually also incorporates the facility to add 90° steps. This feature is especially useful in single phase instruments where the phase is best adjusted by looking for a null at the output and then adding 90° or 270° to maximize the output.

90° Phase-Shift

In dual phase instruments, this section shifts the phase of the output of the phase-shifter by 90° to provide the reference signal drive to the quadrature phase-sensitive detector.

Phase-Sensitive Detector(s)

Single phase instruments have one phase-sensitive detector, or demodulator, whereas dual phase units have two. However the discussion that follows applies equally to both in-phase and quadrature detectors and hence does not differentiate between them.

The PSD serves to multiply the output of the signal channel by the reference signal and may be operated in one of two modes. In the squarewave, or flat, mode, in which the signal channel main filter is bypassed, the multiplying elements consist simply of reversing switches driven at the reference frequency. The Fourier analysis of this operation shows that this type of demodulator gives a steady-state output for any component of the signal channel output at the reference frequency or its odd harmonics, with the gain being inversely proportional to the harmonic number.

The presence of the odd harmonic responses in the squarewave demodulator is undesirable in the majority of experimental situations and is overcome by switching the demodulator to the Walsh mode.

In this mode, the demodulator is implemented by using a more sophisticated set of switches, that may be considered to perform a multiplication of the input signal by a stepwise approximation to a sine wave at the reference frequency. The effect of this is to provide a response to input signals at the fundamental reference frequency and its seventh and higher harmonics, with no response at the third and fifth harmonics.

Additionally, when switched to this mode, the main signal channel filter is switched into use. This gives excellent rejection of the responses at the seventh harmonic and above and hence, in conjunction with the demodulator, provides an

overall lock-in amplifier response which is limited to signals at the reference frequency. Used in this manner the instrument is said to give fundamental, or sine wave, response and it is by far the most common mode of operation.

Output Stages

Output Low-Pass Filters

The output signal from the lock-in amplifier is required to follow in time the variation in the input signal magnitude and phase. The function of the output filter is to reduce the level of spurious time variations, which may be random or deterministic in nature and which are commonly referred to as output noise.

The output filters implement either first-order or second-order low-pass functions (6 dB/octave or 12 dB/octave roll-off respectively) by the use of a combination of analog and digital techniques and are normally specified by means of a time constant.

In traditional audio terminology, a first-order low-pass filter is said to have a roll-off of 6 dB/octave since at frequencies well beyond the passband its gain is inversely proportional to the frequency (a change of 6 dB corresponds to approximately a factor of 2 in amplitude and an octave represents a doubling of frequency); similarly a second-order filter is said to have a 12 dB/octave roll-off.

The 6 dB/octave option is not satisfactory for most purposes since it does not give good rejection of non-random interfering signals which may give aliasing problems in the analog-to-digital converters which follow. However, it is of use when the lock-in amplifier forms part of a feedback loop and when the time-domain response is critical.

Output Amplifier(s)

The instrument's overall full-scale sensitivity is affected by the gains of both the input and output amplifiers. The input amplifiers are AC-coupled, but the output amplifiers are DC-coupled and hence are subject to increasing drift with time and temperature as their gain is increased.

At the highest sensitivity settings, both input and output amplifiers will be operating near to their maximum gain. However, at mid-range sensitivity settings the same overall sensitivity can be obtained by different combinations of AC and DC gain. Lower values of DC gain give better output stability, but at the expense of reducing the instrument's dynamic reserve, since the corresponding higher AC gain results in the demodulator overloading at lower levels of interfering signal.

The instruments are therefore fitted with a control to adjust the gain distribution to best match the applied signals.

Signal Processor

The outputs from the PSDs can be taken directly to the output BNC connectors but are usually subjected to further processing in the digital signal processing section. This digitizes the PSD output signals and can then perform further filtering, and, in the case of dual phase units, derive the overall signal magnitude and phase angle. Once processed, analog outputs can be generated using digital-to-analog converters, although if the signals are to be read from the digital panel meters or via the computer interfaces then this is not of course necessary.

Microprocessor Control

All modern instruments incorporate a microprocessor which is used to implement a number of functions, such as the output low-pass filter and processing stages. However its most common purpose is to allow the instrument to be operated via a standard computer interface such as a GPIB (IEEE-488) or RS232 link.

The command set used in **SIGNAL RECOVERY** units is based on simple mnemonics which generally operate either to adjust or interrogate instrument settings depending on whether an additional optional parameter is sent.

As an example, to set the full-scale sensitivity of the model 5110 to the 2 mV setting requires the user to send the following ASCII character string:-

SEN 13 <CR>

where <CR>, the *terminator*, represents the carriage return character.

To interrogate the instrument's sensitivity setting, the user would send:-

SEN <CR>

and the instrument would respond with:-

13 <CR>

It is therefore very simple to program these instruments remotely and the logical nature of the mnemonics makes user programs easy to read.

Oscillator

Virtually all modern instruments include an internal oscillator which may be used as a source of excitation to the experiment. This generally has a sinusoidal output of adjustable voltage, typically 0 V to 2 V rms, and frequency over the operating range of the instrument. An internal switch allows the oscillator signal to be optionally connected directly to the reference channel, thereby eliminating the need for an external connection.

Other Features

The internal crystal clock and the microprocessor allow the units to measure the reference frequency very accurately and thereby offer the capability of being used as a frequency meter over their operating frequency range.

Many computer-controlled experiments require one or two analog or digital control signals and may generate analog signals which need recording at the same time as the output from the lock-in amplifier. Traditionally this was done by the provision of separate computer interface boxes, but modern instruments simplify the task by the inclusion of both analog and digital auxiliary inputs and outputs. These take advantage of the presence of the A/D and D/A converters and computer interface electronics already in the instrument and can often avoid the need to use separate A/D and D/A converter units.

Further Information

This Technical Note is intended to describe the overall structure of a modern analog lock-in amplifier. Additional information may be found in other **SIGNAL RECOVERY** publications, which may be obtained from your local **SIGNAL RECOVERY** office or representative, or by download from our website at www.signalrecovery.com

- TN 1000 What is a Lock-in Amplifier?
- TN 1001 Specifying Lock-in Amplifiers
- TN 1003 The Digital Lock-in Amplifier
- TN 1004 How to Use Noise Figure Contours
- TN 1005 What is a Boxcar Averager?
- TN 1006 Boxcar Averager Specification Comparison
- TN 1007 The Incredible Story of Dr D.P. Freeze
- AN 1000 Dual-Channel Absorption Measurement with Source Intensity Compensation
- AN 1001 Input Offset Reduction using the Model 7265/7260/7225/7220 Synchronous Oscillator/Demodulator Monitor Output
- AN 1002 Using the Model 7225 and 7265 Lock-in Amplifiers with software written for the SR830
- AN 1003 Low Level Optical Detection using Lock-in Amplifier Techniques
- AN 1004 Multiplexed Measurements using the 7225, 7265 and 7280 Lock-in Amplifier
- AN 1005 Dual Beam Ratiometric Measurements using the Model 198A Mixed Beam Light Chopper

SIGNAL RECOVERY

SIGNAL RECOVERY is part of AMETEK Advanced Measurement Technology, Inc

801 SOUTH ILLINOIS AVENUE
OAK RIDGE
TN 37831-2011
USA

Phone: +1 865 482 4411
Fax: +1 865 483 0396

SPECTRUM HOUSE
1 MILLARS BUSINESS CENTRE, FISHPONDS CLOSE
WOKINGHAM, BERKS RG41 2TZ
UNITED KINGDOM

Phone: +44 (0)118 936 1210
Fax: +44 (0)118 936 1211

E-mail: info@signalrecovery.com

Web Site: www.signalrecovery.com

V5.01/08UK © 2008 AMETEK Advanced Measurement Technology, Inc