

**Models 5105 &  
5106**  
**Dual Phase Lock-in  
Amplifiers**  
*Instruction Manual*  
222044-A-MNL-E

## FCC Notice

This equipment generates, uses, and can radiate radio-frequency energy and, if not installed and used in accordance with this manual, may cause interference to radio communications. As temporarily permitted by regulation, operation of this equipment in a residential area is likely to cause interference, in which case the user at his own facility will be required to take whatever measures may be required to correct the interference.

## Company Names

**SIGNAL RECOVERY** is part of Advanced Measurement Technology, Inc, a division of AMETEK, Inc. It includes the businesses formerly trading as EG&G Princeton Applied Research, EG&G Instruments (Signal Recovery), EG&G Signal Recovery and PerkinElmer Instruments (Signal Recovery)

## Declaration of Conformity

This product conforms to EC Directives 89/336/EEC Electromagnetic Compatibility Directive, amended by 92/31/EEC and 93/68/EEC, and Low Voltage Directive 73/23/EEC amended by 93/68/EEC.

This product has been designed in conformance with the following IEC/EN standards:

EMC:           BS EN55011 (1991) Group 1, Class A (CSPIR 11:1990)  
                  BS EN50082-1 (1992):  
                          IEC 801-2:1991  
                          IEC 801-3:1994  
                          IEC 801-4:1988

Safety:        BS EN61010-1: 1993 (IEC 1010-1:1990+A1:1992)

## Trademarks

AMETEK® and the **AMETEK**® and **A** logos are registered trademarks, and 5105Acquire a trademark, of AMETEK, Inc. Microsoft, MS-DOS, QBASIC and QuickBASIC are registered trademarks and Windows is a trademark of Microsoft Corporation

# Table of Contents

## Chapter One, Introduction

1.1 How to Use This Manual.....	1-1
1.2 What is a Lock-in Amplifier?.....	1-2
1.3 Key Specifications and Benefits.....	1-3

## Chapter Two, Installation & Initial Checks

2.1 Installation - General .....	2-1
2.1.01 Introduction .....	2-1
2.1.02 Rack Mounting - Model K0304.....	2-1
2.1.03 Inspection .....	2-1
2.1.04 External Power Supply for Model 5105 .....	2-1
2.1.05 Line Voltage Selection and Fuses - Model 5105 .....	2-2
2.1.06 External Power for Model 5106 .....	2-3
2.2 Initial Checks.....	2-3
2.2.01 Introduction .....	2-3
2.2.02 Procedure - Model 5105 .....	2-4
2.2.03 Procedure - Model 5106 .....	2-5

## Chapter Three, Technical Description

3.1 Introduction .....	3-1
3.2 Principles of Operation.....	3-1
3.2.01 Block Diagram.....	3-1
3.2.02 Signal-Channel Inputs .....	3-1
3.2.03 Signal Channel Filters .....	3-3
3.2.04 Signal Monitor Output.....	3-4
3.2.05 Reference Channel.....	3-4
3.2.06 Phase Shifter.....	3-5
3.2.07 Reference Monitor.....	3-6
3.2.08 Reference Channel Frequency Range Adjustment .....	3-6
3.2.09 Demodulators - Introduction .....	3-7
3.2.10 Demodulators - Squarewave Mode .....	3-7
3.2.11 Demodulators - Sinewave Mode .....	3-8
3.2.12 Output Filters - Operation.....	3-8
3.2.13 Output Offset.....	3-10
3.2.14 Dynamic Reserve and Output Stability .....	3-10
3.2.15 CH1 and CH2 Analog Outputs.....	3-12
3.2.16 Overload Detection.....	3-12
3.2.17 Analog to Digital Converter .....	3-12
3.2.18 Main Microprocessor - General.....	3-13
3.2.19 Main Microprocessor - Vector Magnitude & Phase.....	3-13
3.2.20 Main Microprocessor - Auto Functions.....	3-14
3.3 General .....	3-16
3.3.01 Accuracy.....	3-16
3.3.02 Power-up Defaults .....	3-16

## Chapter Four, Connections & Controls

4.1 Model 5105 Front Panel.....	4-1
4.1.01 SIGNAL connector.....	4-1
4.1.02 REF IN connector.....	4-1
4.1.03 CH1 and CH2 connectors.....	4-1
4.1.04 POWER LED .....	4-2
4.2 Model 5105 Rear Panel.....	4-2
4.2.01 Power Input Socket .....	4-2
4.2.02 PORT 1 RS232 Connector .....	4-2
4.2.03 PORT 2 RS232 Connector .....	4-2
4.2.04 DEVICE ADDR/BAUD switch .....	4-2
4.2.05 REF. MON Connector.....	4-3
4.2.06 SIG. MON Connector.....	4-3
4.3 Model 5106 PCB Assembly .....	4-3
4.3.01 SIGNAL connecting point (B100) .....	4-4
4.3.02 REF INPUT connecting point (B200).....	4-4
4.3.03 CH1 and CH2 connecting points (B401 and B400).....	4-5
4.3.04 POWER LED .....	4-5
4.3.05 Power Input Socket .....	4-5
4.3.06 PORT 1 RS232 Connector .....	4-6
4.3.07 PORT 2 RS232 Connector .....	4-6
4.3.08 DEVICE ADDR/BAUD switch .....	4-6
4.3.09 REF MON connector (J305) .....	4-6
4.3.10 SIG MON Connector (J400) .....	4-6

## Chapter Five, 5105Acquire Software

5.1 Introduction .....	5-1
5.2 Installation .....	5-1
5.3 Operation .....	5-1
5.3.01 Getting Started.....	5-1
5.3.02 Remote Front Panel - Main Display .....	5-4
5.3.03 Remote Front Panel - Input Tab .....	5-5
5.3.04 Remote Front Panel - Filters Tab .....	5-6
5.3.05 Remote Front Panel - Reference Tab .....	5-6
5.3.06 Remote Front Panel - Output Tab .....	5-6

## Chapter Six, Computer Operation

6.1 Introduction .....	6-1
6.2 RS232 Operation .....	6-1
6.2.01 Introduction .....	6-1
6.2.02 RS232 Interface - General Features .....	6-1
6.2.03 Auxiliary RS232 Interface.....	6-2
6.2.04 Handshaking and Echoes.....	6-2
6.2.05 Terminators .....	6-3
6.2.06 Command Format.....	6-4

---

6.2.07 Delimiters .....	6-4
6.2.08 Compound Commands .....	6-4
6.2.09 Status Byte, Prompts and Overload Byte .....	6-4
6.3 Command Descriptions .....	6-5
6.4.01 Signal Channel.....	6-5
6.4.02 Reference Channel.....	6-6
6.4.03 Signal Channel Output Filters .....	6-7
6.4.04 Signal Channel Output Amplifiers .....	6-7
6.4.05 Instrument Outputs .....	6-8
6.4.06 Computer Interface .....	6-10
6.4.07 Instrument Identification .....	6-11
6.5 Programming Examples .....	6-12
6.5.01 Introduction .....	6-12
6.5.02 Converting Output Values to Voltages.....	6-12
6.5.03 Basic Signal Recovery.....	6-12

## Appendix A, Specifications

### Appendix B, Pinouts

B.1 RS232 Connector Pinout .....	B-1
B.2 Preamplifier Power Connector Pinout .....	B-1

### Appendix C, Demonstration Programs

C.1 Simple Terminal Emulator.....	C-1
C.2 RS232 Control Program with Handshakes .....	C-1

### Appendix D, Cable Diagrams

D.1 RS232 Cable Diagrams.....	D-1
-------------------------------	-----

### Appendix E, Alphabetical Listing of Commands

### Index

Warranty .....	End of Manual
----------------	---------------



## 1.1 How to Use This Manual

This manual gives detailed instructions for setting up and operating a **SIGNAL RECOVERY** model 5105 or 5106 dual phase lock-in amplifier. It is split into the following chapters:-

### **Chapter 1 - Introduction**

Provides an introduction to the manual, briefly describes what a lock-in amplifier is and the types of measurements it may be used for, and describes the differences between the models 5105 and 5106. Finally, it lists the major specifications of these instruments.

### **Chapter 2 - Installation and Initial Checks**

Describes how to install one of these instruments and gives a simple test procedure which may be used to check that it has arrived in full working order.

### **Chapter 3 - Technical Description**

Provides an outline description of the design of the instruments and discusses the effect of the various controls. A good understanding of the design will enable the user to get the best possible performance from the units.

### **Chapter 4 - Connections & Controls**

Describes the function of the connectors and switch and found on the instruments.

### **Chapter 5 - 5105Acquire Software**

This chapter describes how to operate the instruments from the supplied Windows XP/Vista compatible software, 5105Acquire.

### **Chapter 6 - Computer Operation**

This chapter provides detailed information on operating the instruments from a computer via the RS232 interfaces. It includes information on how to establish communications, the functions available, the command syntax and a detailed command listing.

### **Appendix A**

Gives detailed specifications for both units.

### **Appendix B**

Details the pinouts of the instruments' multi-way connectors.

### **Appendix C**

Lists two simple terminal programs which may be used as the basis for more complex user-written programs.

### **Appendix D**

Shows the connection diagrams for suitable RS232 null-modem cables to couple the units to an IBM-PC or 100% compatible computer.

### **Appendix E**

Gives an alphabetical listing of the computer commands for easy reference.

New users are recommended to unpack the instrument and carry out the procedure in chapter 2 to check that it is working satisfactorily. They should then make themselves familiar with the information in chapters 3, 4 and 5, even if they intend to eventually write their own software. Only when they are fully conversant with operation from the supplied software should they then turn to chapter 6 for information on how to use the instrument remotely. Once the structure of the computer commands is familiar, appendix E will prove convenient as it provides a complete alphabetical listing of these commands in a single easy-to-use section.

## **1.2 What is a Lock-in Amplifier?**

In its most basic form the lock-in amplifier is an instrument with dual capability. It can recover signals in the presence of an overwhelming noise background or alternatively it can provide high resolution measurements of relatively clean signals over several orders of magnitude and frequency. They are widely used in many fields of scientific research, such as optics, electrochemistry, materials science, fundamental physics and electrical engineering, as units which can provide the optimum solution to a large range of measurement problems.

The model 5105 is a compact, low-cost module, that allows these advantages to be gained in an even wider range of experiments than before. It is a complete instrument, supplied with software, an RS232 cable to connect it to a PC and a separate power supply module.

In cases where the user wishes to build the capabilities of the instrument into their own equipment then the model 5106 may be more suitable. This is simply the tested PCB assembly from the model 5105 but apart from the lack of an external case it has identical specifications. The model 5106 is supplied with software and RS232 cable, but without a power supply module, since in many cases suitable power is already available in the user's system. Where this is not the case then the power module may, of course, be purchased as an additional item.

The models 5105 and 5106 lock-in amplifiers can function as a:-

- ◆ AC Signal Recovery Instrument
- ◆ Phase Meter
- ◆ Vector Voltmeter
- ◆ Frequency Meter

These characteristics, all available in a single compact package, make them invaluable additions to any laboratory.

## 1.3 Key Specifications and Benefits

The **SIGNAL RECOVERY** Models 5105 and 5106 represent a cost-effective solution to many requirements for phase sensitive detection and offer:-

- ◆ Frequency range: 5 Hz to 20 kHz  
or one single (“spot”) frequency in the range  
20 kHz to 100 kHz by factory calibration
- ◆ Voltage sensitivity: 10  $\mu$ V to 1 V full-scale in 1 -3.16 - 10 (10 dB) steps
- ◆ Low-Pass and High-Pass Pass Signal Channel Filters
- ◆ Dual phase demodulator with X-Y analog, and X-Y, R- $\theta$  digital, outputs
- ◆ Auto phase control
- ◆ Output time constants: 300  $\mu$ s to 10 s
- ◆ Output offset control
- ◆ Standard RS232 interface with RS232 daisy-chain capability to allow up to 15 instruments to be controlled from a single computer port



# Installation & Initial Checks

## 2.1 Installation - General

As mentioned in chapter 1, the only difference between the models 5105 and 5106 is the fact that the former is a complete module in an instrument case while the latter is a tested PCB assembly. Consequently, in the procedure that follows sections that apply to only one of the instruments are clearly identified.

### 2.1.01 Introduction

Installation of the model 5105 or 5106 is generally very simple. Because of their low power consumption, the units do not incorporate forced-air ventilation. With an ambient operating temperature range of 0 °C to 35 °C, they are highly tolerant to environmental variables and in the case of the model 5105 need only to be protected from exposure to corrosive agents and liquids.

The 5106, as a tested circuit board, needs suitable protection from mechanical damage.

***CAUTION: Many of the electronic components used in the model 5106 are static sensitive and damage to these components may result if the card is handled without suitable static protection by the handler. Static damage to the 5106 by mishandling will void any warranty. See Warranty statement at the end of this manual***

### 2.1.02 Rack Mounting - Model K0304

An optional accessory kit, part number K02003, is available from **SIGNAL RECOVERY** to allow the model 5105 to be mounted in a standard 19-inch rack.

### 2.1.03 Inspection

Upon receipt the instrument should be inspected for shipping damage. If any is noted, **SIGNAL RECOVERY** should be notified immediately and a claim filed with the carrier. The shipping container should be saved for inspection by the carrier.

### 2.1.04 External Power Supply for Model 5105

The model 5105 is supplied with an external power supply module, model PS0108, shown below in figure 2-1. This unit may also be purchased as an optional extra with the model 5016.

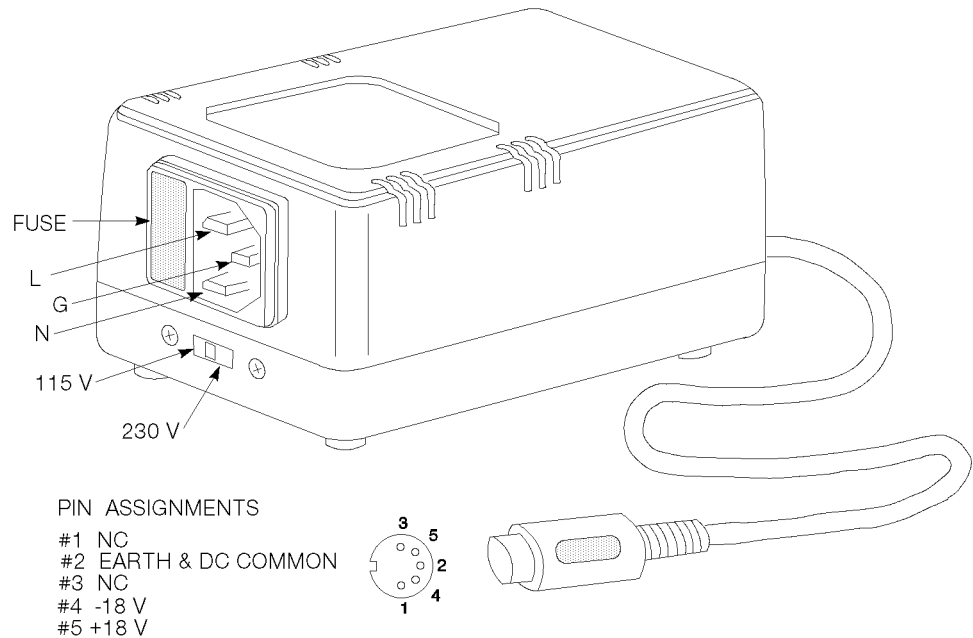

**Figure 2-1, External Power Supply**

This has a standard IEC 320 socket is mounted on the side panel and a suitable line cord is supplied.

### 2.1.05 Line Voltage Selection and Fuses - Model 5105

Before plugging in the external power supply line cord, ensure that it is set to the voltage of the AC power supply to be used.

A detailed discussion of how to check and, if necessary, change the line voltage setting follows.

**CAUTION:** *The power supply module may be damaged if the line voltage is set for 115 V AC operation and it is turned on with 230 V AC applied to the power input connector.*

The power supply can operate from one of two different line voltage ranges, 100-130 V, and 220-260 V, at 50-60 Hz. Units are normally shipped from the factory with the line voltage selector set to 100-130 V AC, unless they are destined for an area known to use a line voltage in the 220-260 V range, in which case, they are shipped configured for operation from the higher range. The change from one range to another is made by using a small screwdriver to reposition a slide switch located on the end-panel of the power supply just below the IEC power input assembly. When the switch is set to **230V**, the supply is configured for the higher voltage range, and when set to **115V** it is configured for the lower voltage range.

Next check the fuse rating. For operation from a nominal line voltage of 115 V, use a 20 mm slow-blow fuse rated at 1.0 A, 250 V. For operation from a nominal line voltage of 230 V, use a 20 mm slow-blow fuse rated at 0.5 A, 250 V.

To change the fuse, remove the line power cord and use a small screwdriver to withdraw the fuse holder. Remove the fuse and replace with a slow-blow fuse of the correct voltage and current rating. Install the fuse holder by sliding it into place. Ensure that only fuses with the required current and voltage ratings and of the specified type are used for replacement. The use of makeshift fuses and the short-circuiting of fuse holders is prohibited and potentially dangerous.

### 2.1.06 External Power for Model 5106

The model 5106 requires a dual -rail regulated or unregulated DC external power supply of +18 to +21 V @ 300 mA and -18 to -21 V @ 80 mA. This power is applied to the 180° DIN power input socket towards the rear of the board (figure 2-2) by means of a suitable plug.

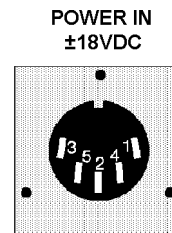

Figure 2-2, Power Input Connector

The pin allocation of this connector is as follows:

Pin	Function
1	No Connection
2	Ground/Earth
3	No Connection
4	-18 V
5	+18 V

The mating plug is SWITCHCRAFT® type 05BL5M or equivalent (**SIGNAL RECOVERY** part number 2102-0171).

## 2.2 Initial Checks

### 2.2.01 Introduction

The following procedure checks the performance of the model 5015 or 5106. In general, it should be carried out after inspecting the instrument for obvious shipping damage.

**NOTE:** Any damage must be reported to the carrier and to **SIGNAL RECOVERY** immediately. In addition the shipping container must be retained for inspection by the carrier.

Note that this procedure is intended to demonstrate that the instrument has arrived in good working order, not that it meets specifications. Each instrument receives a careful and thorough checkout before leaving the factory, and normally, if no

shipping damage has occurred, will perform within the limits of the quoted specifications. If any problems are encountered in carrying out these checks, contact **SIGNAL RECOVERY** or the nearest authorized representative for assistance.

## 2.2.02 Procedure - Model 5105

- 1) Plug one end of the supplied RS232 cable into the connector marked **PORT 1** on the rear of the instrument, and the other end into a free serial port on a PC compatible computer.
- 2) Ensure that the external power supply is set to the line voltage of the power source to be used, as described in section 2.1.05.
- 3) Plug the 5-pin DIN plug on the power supply's power output lead into the **POWER IN** connector on the rear of the 5105, plug the matching end of the line power cord into the power supply module and plug the other end into to an appropriate line source.
- 4) The red **POWER LED** on the front panel of the instrument should glow, indicating that it is receiving power.
- 5) Connect one BNC cable between the output of a function generator and a BNC "tee" piece on the 5105's front panel **REF IN** connector. Connect a second cable from this tee piece to the 5105's **SIGNAL** connector and set the function generator so that its output is a 1 kHz sine-wave of 1 V rms (2.8 V pk-pk) amplitude.
- 6) Insert the supplied 5105Acquire Setup Disk 1 into the into a suitable disk drive on the computer and from the Windows Start menu select the Run item.
- 7) Type `a:setup` and press the RETURN or ENTER key to start the software installation procedure. Of course, if the disk drive being used has a different drive letter then simply substitute this for the letter "a" in this line.
- 8) Start the 5105Acquire software by selecting the 5105Acquire item from the Start Programs menu.
- 9) When the software starts for the first time, it will display the Instrument Connections dialog. Click on the **Find Instruments** button to search for the model 5105. If required, the default instrument descriptions can be changed so that they are meaningful in your experiment. For example, descriptions such as "photocurrent", "sample voltage" or "temperature" could be used.  
  
Clicking on the **OK** button closes the dialog and the main display appears.
- 10) If communications are not established, verify that the RS232 cable connections are correct, that the serial port is not already opened by another application and that the instrument is powered on. Finally, click on the **Find Instruments** button again to search for the instrument.
- 11) Once the main window is displayed, select the **Hardware, Control 5105 xxxx** menu item (where xxxx is the instrument description), which open a remote front

panel for the lock-in amplifier. This takes the form of a tabbed dialog box, similar to that shown in figure 2-3, which allows the instrument controls to be adjusted and the measured outputs to be displayed.

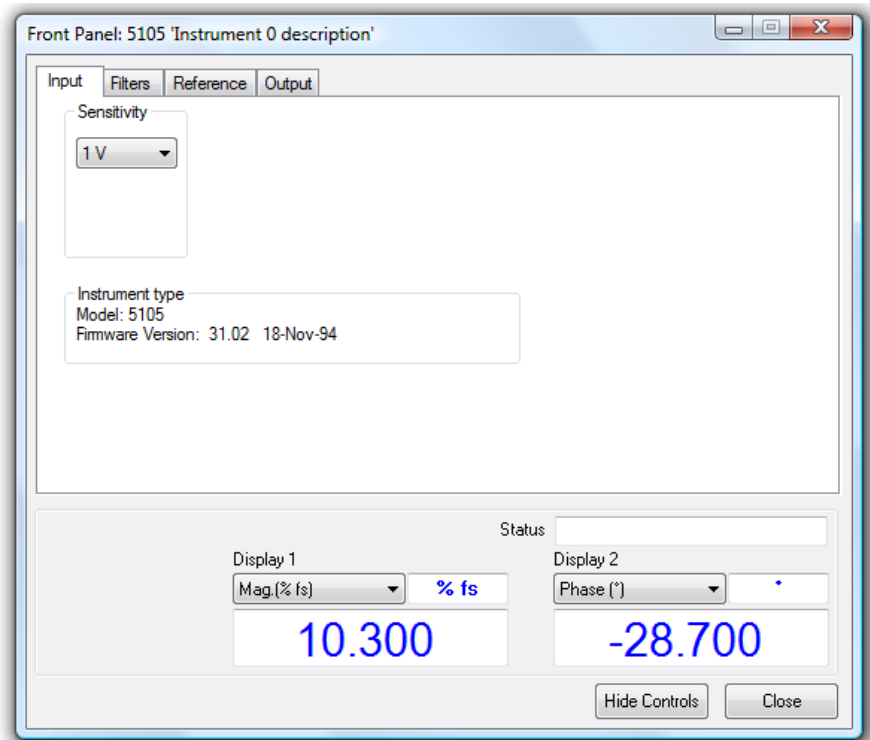

Figure 2-3, 5105Acquire Software Remote Front Panel

- 12) On the Input tab, check that the sensitivity is set to 1 V full scale and on the Filters tab, set the High Pass filter to 1 Hz and the Low Pass filter to 50 kHz. Use the controls on the Output tab to set the Dynamic Reserve to Normal, the Slope to 12 dB/octave and the Time Constant to 100 ms. Finally, click on the Reference tab and operate the Auto Phase button. This will adjust the reference phase control so that the X-channel output is maximized and the Y-channel output is minimized.
- 13) Use the display selector drop-down lists on the lower section of the window to set the displayed outputs to X% and Y% respectively, and confirm that the left-hand meter is close to 100% and the right hand meter close to zero (i.e. the sinusoidal input of 1 kHz and 1 V rms is being measured with a full-scale sensitivity of 1 V)

This completes the initial checks. Even though the procedure leaves many functions untested, if the indicated results were obtained then the user can be reasonably sure that the unit incurred no hidden damage in shipment and is in good working order.

### 2.2.03 Procedure - Model 5106

**CAUTION:** Many of the electronic components used in the model 5106 are static sensitive and damage to these components may result if the card is handled without suitable static protection by the handler. Static damage to the 5106 by mishandling

*will void any warranty. See Warranty statement at the end of this manual*

- 1) Plug one end of the supplied RS232 cable into the connector marked **PORT 1** on the rear of the 5106 PCB assembly, and the other end into a free serial port on a suitable computer.
- 2) Prepare two lengths of 50  $\Omega$  coaxial cable by fitting one end of with a 50  $\Omega$  BNC plug and stripping the other end back to form separate inner and outer connections.
- 3) Refer to figure 3-2 in chapter 3 and connect one of the prepared cables to the solder pads on the PCB identified as B100, SIGNAL input. Connect the second cable to the REF IN pads, B200. Take care to ensure that the braid, or outer of the coax, goes to the pads marked "Gnd", with the inner to the pads marked "Signal".
- 4) Apply a suitable source of DC power to the DIN power input connector as described in section 2.1.06.
- 5) The red **POWER LED** on the front edge of the PCB should glow, indicating that it is receiving power.
- 6) Connect the cable from the B100 pads on the 5106 to a BNC "tee" piece on the output of a function generator. This is the signal input to the 5106. Connect the cable from the second set of pads, marked B200 on the 5106, which is the reference input to the other side of the tee piece. Set the function generator so that its output is a 1 kHz sine-wave of 1 V rms (2.8 V pk-pk) amplitude.
- 7) Insert the supplied 5105Acquire Setup Disk 1 into the into a suitable disk drive on the computer and from the Windows Start menu select the Run item.
- 8) Type `a:setup` and press the RETURN or ENTER key to start the software installation procedure. Of course, if the disk drive being used has a different drive letter then simply substitute this for the letter "a" in this line.
- 9) Start the 5105Acquire software by selecting the 5105Acquire item from the Start Programs menu.
- 10) When the software starts for the first time, it will display the Instrument Connections dialog. Click on the **Find Instruments** button to search for the model 5105. If required, the default instrument descriptions can be changed so that they are meaningful in your experiment. For example, descriptions such as "photocurrent", "sample voltage" or "temperature" could be used.

Clicking on the **OK** button closes the dialog and the main display appears.

- 11) If communications are not established, verify that the RS232 cable connections are correct, that the serial port is not already opened by another application and that the instrument is powered on. Finally, click on the **Find Instruments** button again to search for the instrument.

- 12) Once the main window is displayed, select the **Hardware, Control 5106 xxxx** menu item (where xxxx is the instrument description), which opens a remote front panel for the lock-in amplifier. This takes the form of a tabbed dialog box, similar to that shown in figure 2-3, which allows the instrument controls to be adjusted and the measured outputs to be displayed.
- 13) On the Input tab, check that the sensitivity is set to 1 V full scale and on the Filters tab, set the High Pass filter to 1 Hz and the Low Pass filter to 50 kHz. Use the controls on the Output tab to set the Dynamic Reserve to Normal, the Slope to 12 dB/octave and the Time Constant to 100 ms. Finally, click on the Reference tab and operate the Auto Phase button. This will adjust the reference phase control so that the X-channel output is maximized and the Y-channel output is minimized.
- 14) Set the display to XY % and confirm that the left-hand meter is close to 100% and the right hand meter close to zero (i.e. the sinusoidal input of 1 kHz and 1 V rms is being measured with a full-scale sensitivity of 1 V)

This completes the initial checks. Even though the procedure leaves many functions untested, if the indicated results were obtained then the user can be reasonably sure that the unit incurred no hidden damage in shipment and is in good working order.



### 3.1 Introduction

The models 5105 and 5106 lock-in amplifiers represent a significant advance in signal recovery instrumentation, allowing phase sensitive detection to be used in applications where hitherto it would have been too expensive to consider. They are also particularly suitable in traditional chopped light measurement systems and for educational use in teaching the principles of lock-in amplifier detection.

This chapter discusses design of the instrument by considering it as a series of functional blocks. In addition to describing how each block operates, each section also includes information on the effect of the various controls. Throughout this chapter the model number 5105 can be taken to include the model 5106, except where otherwise stated.

### 3.2 Principles of Operation

#### 3.2.01 Block Diagram

The model 5105 uses low-noise analog signal processing circuitry and a 68000 series microprocessor to achieve its specifications. A block diagram of the instrument is shown in figure 3-1, and the sections that follow describe how each functional block operates and the effect it has on the instrument's performance.

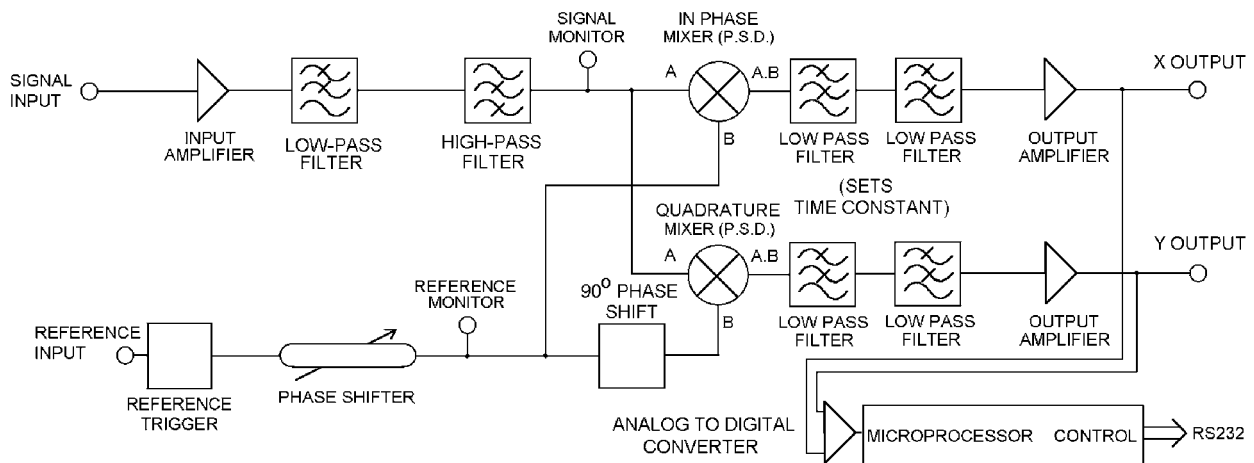

Figure 3-1, Model 5105 - Block Diagram

#### 3.2.02 Signal-Channel Inputs

The signal input amplifier can be configured for either single-ended or pseudo-differential voltage mode operation and is always AC coupled. In the pseudo-differential mode the signal input “ground” connection is not directly connected to the instrument chassis ground but rather is returned via a 1 k $\Omega$  resistor.

The specification defined as the Common Mode Rejection Ratio, CMRR, defines how well the instrument rejects common mode signals applied to the input when it is

configured as a pseudo-differential stage. It is usually given in decibels. Hence a specification of 40 dB implies that a common mode signal (i.e. a signal simultaneously applied to both the inner and outer of the 5105's **SIGNAL** input connector, or to the signal and ground connection points on the 5106) of 1 V will give rise to less than 10 mV of signal out of the input amplifier.

### Input Mode Selection

The input mode can be changed by repositioning a jumper, J100, that is mounted on the PCB assembly. To check, and if necessary change the setting, proceed as follows:

- 1) Disconnect all cables from the instrument, including the power input cable.
- 2) If the instrument is a model 5105, remove the four screws, two on each side of the case, that hold the case together and lift off the top of the case.
- 3) Refer to figure 3-2 and identify the position of jumper J100 close to the signal input.

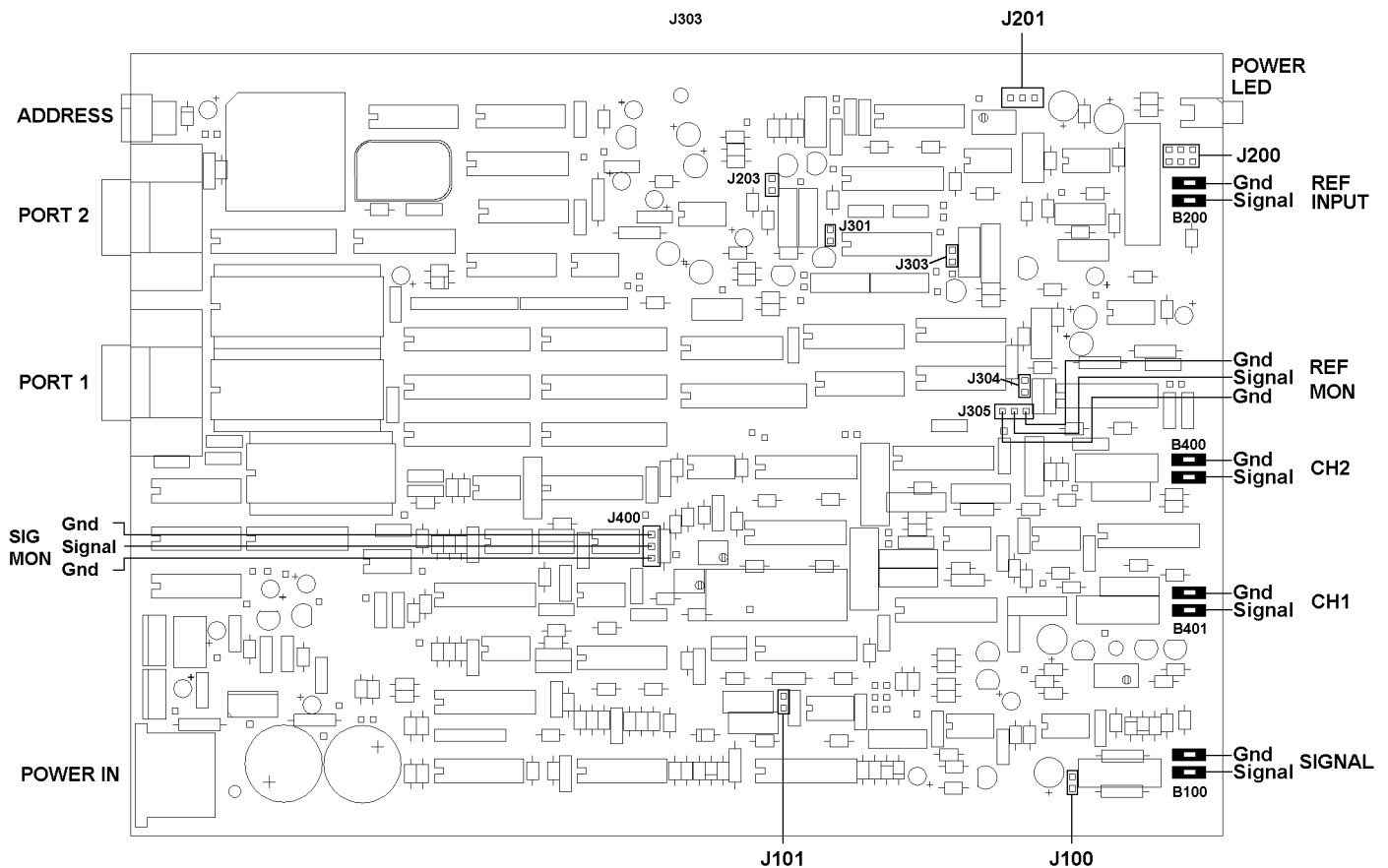

Figure 3-2, Model 5105/5106 PCB Assembly - Component Side

- 4) To set the input to single-ended voltage mode, position the jumper so that the two pins of J100 are linked, and to set it to pseudo-differential mode, position the jumper so that it is on only one of the pins.

- 5) If the instrument is a model 5105, reassemble the instrument case.
- 6) This completes the procedure for configuring the signal channel input mode.

### 3.2.03 Signal Channel Filters

There are two signal channel filters, identified as the High Pass and Low Pass filters. These filters can prevent large interfering signals, which would otherwise cause overload and non-linear operation, from reaching the phase sensitive detectors (PSDs) and thereby increases the instruments' *dynamic reserve* (discussed later in section 3.3.14). The low-pass filter also has the effect of modifying the instruments' response from a squarewave mode in that it causes rejection of the higher harmonics of non-sinusoidal input signals, thereby reducing the overall response of the lock-in amplifier to such signals.

#### Low Pass Filter

The low pass filter allows signals below the selected cut-off frequency to pass, and increasingly attenuates signals as the frequency is increased above this value. It should therefore be set so that the cut-off frequency is higher than the frequency of the signal to be measured.

Standard units are supplied with the filter configured to offer the following options, as selected by the LPF [n] command:

n	Selection
0	50 Hz
1	500 Hz
2	5 kHz
3	50 kHz

However, units supplied calibrated to operate at a single (spot) frequency in the range 20 kHz to 100 kHz have modified filter settings, as follows:

n	Selection
0	220 Hz
1	2.2 kHz
2	22 kHz
3	220 kHz

To check, and if necessary change, the available low-pass filter frequencies, use the following procedure:

- 1) Disconnect all cables from the instrument, including the power input cable.
- 2) If the instrument is a model 5105, remove the four screws, two on each side of the case, that hold the case together and lift off the top of the case.
- 3) Refer to figure 3-2 and identify the position of jumper J101.
- 4) To set the low pass filter to the standard mode, position the jumper so that the two pins of J101 are linked, and to set it to the higher frequency range, position the jumper so that it is on only one of the pins.

- 5) If the instrument is a model 5105, reassemble the instrument case.
- 6) This completes the procedure for configuring the available low-pass filter frequencies.

#### **High Pass Filter**

The high-pass filter allows signals above the selected cut-off frequency to pass, and increasingly attenuates signals as the frequency is decreased below this value. It should therefore be set so that the cut-off frequency is lower than the frequency of the signal to be measured.

The filter offers the following options, as selected by the HPF [n] command:

n	Selection
0	10 Hz
1	100 Hz
2	1 kHz
3	10 kHz

In summary, the filters should be set so that they “bracket” the frequency of interest.

### **3.2.04 Signal Monitor Output**

The analog signal following the input amplifier and signal channel filters is available at the rear-panel **SIG. MON** BNC connector, in the case of the model 5105, or by connection to J400 on the model 5106. Because of the operation of the algorithm that distributes the overall gain between the signal channel and the output filters, the gain between the signal input and this connector depends on a number of factors. These include the full-scale sensitivity range, the main signal channel filter setting, the setting of the dynamic reserve control and the setting of the output filter time-constants. This should be taken into account when using the signal monitor output to monitor correct lock-in amplifier operation or to implement a stand-alone tuned amplifier.

The signal monitor output is unbuffered, and has an output impedance of 1 k $\Omega$ . As such, it should not be connected to loads of less than 15 k $\Omega$ . Internal noise and switching spikes may be present. The higher the reserve setting, the greater their amplitude will be relative to that of the signal.

The output of the signal channel is fed to the signal inputs of the in-phase and quadrature phase sensitive detectors (PSDs). Before discussing these in detail and the output stages that follow, the reference channel that provides the other input to the demodulators will be described.

### **3.2.05 Reference Channel**

The reference channel in the instrument is responsible for implementing the reference trigger/phase-locked loop and phase shifter circuits and providing switching waveforms to the phase sensitive detectors.

The input to the reference channel can be configured to accept either a TTL logic signal or an analog waveform with a 50:50 mark:space ratio. Whenever possible, the

TTL mode should be used since it gives better phase accuracy.

To check, and if necessary change the reference input mode, use the following procedure:

- 1) Disconnect all cables from the instrument, including the power input cable.
- 2) If the instrument is a model 5105, remove the four screws, two on each side of the case, that hold the case together and lift off the top of the case.
- 3) Refer to figure 3-2 and identify the position of jumpers J200 and J201.
- 4) To set the reference input mode to TTL, position the jumpers as shown in figure 3-3, and to set it to the analog input mode, position them as shown in figure 3-4.

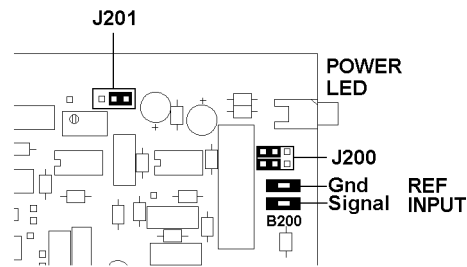

**Figure 3-3, Jumper Settings for TTL Reference Input Mode**

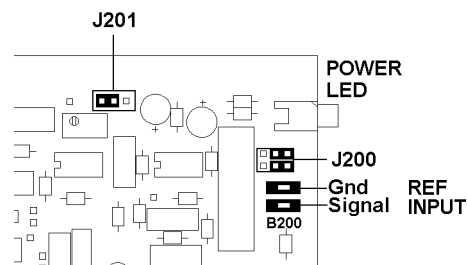

**Figure 3-4, Jumper Settings for Analog Reference Input Mode**

- 5) If the instrument is a model 5105, reassemble the instrument case.
- 6) This completes the procedure for configuring the low pass filter.

The reference circuit measures the actual reference frequency using the instrument's internal crystal oscillator clock. The time needed for the reference circuits to acquire lock following a change in frequency, the *lock acquisition time*, is nominally 2 reference periods plus 1 s. The instrument reports when the reference is unlocked by the response to the ST command.

### 3.2.06 Phase Shifter

The reference channel also implements the reference phase shifter, allowing the phase of the reference inputs to the demodulators be adjusted to the required value, with a setting resolution of  $0.1^\circ$ . The reference phase is defined as the phase of the reference input to the in-phase demodulator with respect to a sinusoidal reference

input.

This means that when the reference phase is zero and the signal input to the demodulator is a full-scale sinusoid in phase with the reference input sinusoid, the output of the in-phase, or X channel, demodulator is a full-scale positive value and the quadrature, or Y channel, demodulator output is zero.

The reference input circuit actually detects a positive-going crossing of the mean value of the applied reference voltage. Therefore when the reference input is not sinusoidal, its effective phase is the phase of a sinusoid with positive-going zero crossing at the same point in time, and accordingly the reference phase is defined with respect to this waveform.

In basic lock-in amplifier applications the purpose of the experiment is to measure the amplitude of a signal which is of fixed frequency and whose phase with respect to the reference input does not vary. This is a *scalar* measurement, for example the measurement of the response of a system to a chopped optical beam. Many other lock-in amplifier applications are of the *signed scalar* type. In these, the purpose of the experiment is to measure the amplitude and sign of a signal which is of fixed frequency and whose phase with respect to the reference input does not vary apart from reversals of phase corresponding to changes in the sign of the signal. A well known example of this situation is the case of a resistive bridge, one arm of which contains the sample to be measured. Other examples occur in derivative spectroscopy, where a small modulation is applied to the angle of the grating (in optical spectroscopy) or to the applied magnetic field (in magnetic resonance spectroscopy). Double beam spectroscopy is a further common example.

In these signed scalar measurements the phase shifter must be set, after removal of any zero errors, to maximize the X channel or the Y channel demodulator outputs. This is the only method that will give correct operation as the output signal passes through zero, and is also the best method to be used in an unsigned scalar measurement where any significant amount of noise is present.

The output from the phase shifter is directly connected to the reference input of the in-phase demodulator, and, via a further fixed 90° phase shifter to the reference input of the quadrature demodulator.

### 3.2.07 Reference Monitor

A rear-panel **REF. MON** BNC connector, in the case of the model 5105, or a connection to J305 in the case of the model 5106, provides a TTL waveform at the applied reference frequency which can be used to monitor correct reference channel operation. Note that the phase of this waveform with respect to the applied reference is affected by the setting of the reference phase shifter.

### 3.2.08 Reference Channel Frequency Range Adjustment

Standard instruments are supplied calibrated for use with reference frequencies in the range 5 Hz to 20 kHz, but units are also available calibrated for a single (spot) frequency in the range 20 kHz to 100 kHz. In the latter case the reference channel is configured for operation from the higher range by repositioning four internal jumper settings.

To check, and if necessary change the reference frequency range, use the following procedure:

- 1) Disconnect all cables from the instrument, including the power input cable.
- 2) If the instrument is a model 5105, remove the four screws, two on each side of the case, that hold the case together and lift off the top of the case.
- 3) Refer to figure 3-2 and identify the position of the four jumpers J203, J301, J303 and J304.
- 4) To set the reference frequency range to the default 5 Hz to 20 kHz setting, position the four jumpers so that for each one of them the two pins are linked, and to set to the higher frequency range, position the jumpers so each one is on only one pin.
- 5) If the instrument is a model 5105, reassemble the instrument case.
- 6) This completes the procedure for configuring the reference frequency range.

***NOTE: Changing the reference frequency range does not change the calibration of the signal channel. Units supplied calibrated for the standard range may be configured to operate in the higher range by using this procedure, but will not be calibrated at these frequencies. Such calibration can only be performed by SIGNAL RECOVERY***

### 3.2.09 Demodulators - Introduction

Since the 5105 is a dual-phase instrument, there are two phase sensitive detectors (PSDs) or demodulators, one driven in quadrature to the other.

There are various ways of implementing such elements in an analog instrument, but in the 5105 they are based on FET switches giving excellent performance at reasonable cost. Although they are squarewave demodulators, in that they respond to signals not only at the reference frequency but at odd harmonics of it, in conjunction with the low-pass signal channel filter they can give an overall response which is predominantly sinusoidal.

### 3.2.10 Demodulators - Squarewave Mode

Squarewave demodulator operation is implied when the low-pass filter setting is a frequency much greater than the applied reference frequency, e.g. a setting of 50 kHz when using a 300 Hz reference.

The outputs of the reference channel are squarewaves at the fundamental frequency of the reference input voltage, with a phase difference of 90 degrees between the channels. The multiplying elements consist of reversing switches under the control of the squarewaves generated by the reference channel. In practice each reversing switch consists of a two-way switch which causes the signal path to be connected alternately to the output of the signal channel and the output of an inverting amplifier (i.e. an amplifier with transfer function equal to -1) the input of which is connected to the output of the signal channel. Functionally, this arrangement acts as an analog

multiplier which multiplies the output of the signal channel with a demodulation function consisting of a reference-derived squarewave having the two values 1 and  $-1$ . The Fourier analysis of this waveform consists of the fundamental and all odd harmonics, the amplitude of the  $n$ th harmonic being proportional to  $1/n$ . (Note that the fundamental is regarded as the first harmonic). It can be shown that the squarewave demodulator gives a steady-state output resulting from any Fourier component of the signal channel output which is at the fundamental frequency of the reference input voltage or any of its odd harmonics, with the response being inversely proportional to the harmonic number. Also, interfering signal voltages at frequencies close to the odd-harmonic frequencies can cause unwanted beat frequencies at the output.

### 3.2.11 Demodulators - Sinewave Mode

The squarewave demodulator is simple to implement and (because the multiplication is performed only by switches) is capable of excellent performance at low cost. However, in the majority of experimental situations the odd-harmonic responses of the squarewave demodulator are undesirable because they implement “windows” in the frequency domain response through which interfering voltages at or near the odd harmonics of the reference frequency can cause output errors, in the form of static offsets or low-frequency beats.

In the model 5105 the harmonics of the input signal can in many cases be attenuated by the signal channel low-pass filter. Hence the instruments’ response to such harmonics is reduced, giving a response which is mainly to signals at the reference frequency.

For best results, it is important to set the filter frequencies so that they “bracket” the frequency of interest.

### 3.2.12 Output Filters - Operation

The time variation of the output of the lock-in amplifier should represent the time variation of the magnitude and phase of the required input signal. The function of the output filters is to reduce the level of spurious (i.e. unwanted, non-information bearing) time variations, commonly referred to as output noise which may be random or deterministic in nature. One inevitable source of deterministic output noise results from the shape of the signal waveform. For example, the familiar rectified sinusoid waveform with mean value of unity varies from zero to  $(\pi/2)$  twice in each cycle. A second-order filter with time constant equal to the period of the sinusoid will reduce the time variation to about  $\pm 0.02$ , and a filter with three times this time constant will leave a time variation less than  $\pm 0.002$ . Where the residual fluctuation is less than 1 least significant bit of the output analog to digital converter (ADC), a noise-free input sinusoid gives rise to a noise-free digital output. However, where additive noise (random or deterministic) is present, the output time constant will normally be increased to a value which reflects a compromise between output noise and response time. Note that for rejection of deterministic noise the second-order output filter is greatly superior to the first-order filter for equivalent response time.

If the noise process is random with an approximately flat spectrum (white noise) then the root-mean-square value of the output noise is inversely proportional to the square root of the time-constant of the output filters.

The output filters used in the model 5105/5106 implement first-order or second-order low-pass functions, specified by the value of the time constant. For time-constant values in the range 300  $\mu$ s to 1 s, the output filters are conventional analog stages implemented with resistors, capacitors and operational amplifiers. Each filter has two identical first-order low-pass sections, one of which can be switched out, allow it to be used optionally as a first-order filter or as a second-order filter with two equal time constants.

The instruments also offer time constants of 3 s and 10 s, implemented digitally in the output processor and hence available only for output values returned via the RS232 interface.

***NOTE: The maximum time constant available at the analog CH1 and CH2 outputs is 1 s.***

The selected time constant also affects the available range of full-scale sensitivity settings and the outputs (i.e. the analog CH1 and CH2 outputs or the digital responses to computer commands) that can be used. This is because a secondary function of the output filters is to give some additional gain, and at shorter time constants there is less gain. The overall effect is as follows:

**Time Constant = 300  $\mu$ s to 10 ms**

Analog and Digital outputs but only with Sensitivity settings in range of 316  $\mu$ V to 1 V. This is known as the FAST mode.

**Time Constant = 30 m to 1 s**

Analog and Digital outputs at all Sensitivity settings.

**Time Constant = 3 s and 10 s**

Digital outputs only at all Sensitivity settings.

The order of the output filters is controlled by the XDB command and described in terms of a slope, which may seem somewhat strange, and a few words of explanation may be helpful.

In traditional audio terminology, a first-order low-pass filter is described as having "a slope of 6 dB per octave" because in the high-frequency limit its gain is inversely proportional to frequency (6 dB is approximately a factor of 2 in amplitude and an octave is a factor of 2 in frequency); similarly a second-order low-pass filter is described as having "a slope of 12 dB per octave". These terms have become part of the accepted terminology relating to lock-in amplifier output filters and are used in the 5105/5016.

Accordingly the XDB command has options of 6 dB and 12 dB. The 6 dB/octave option is not satisfactory for most purposes because it does not give good rejection of non-random interfering signals which can cause aliasing problems with the instrument's analog-to-digital converters. However, the 6 dB/octave filter finds use where the lock-in amplifier is incorporated in a feedback control loop, and in some situations where the form of the time-domain response is critical. The user is recommended always to use 12 dB/octave unless there is some definite reason for not doing so.

### 3.2.13 Output Offset

Even when the input to the signal channel is nominally zero, the X-channel and Y-channel demodulator outputs may show non-zero values. This phenomenon is called zero error and is usually caused by unwanted coupling or crosstalk between the signal channel and the reference channel, either in the external connections or possibly (in the most sensitive ranges and at the highest reference frequencies) within the instrument itself. Zero errors may also be caused by the effects of changing ambient temperature on the demodulator hardware although these are usually negligible in the case of modern designs such as the model 5105/5106. The magnitudes of any zero errors are usually dependent on the reference frequency.

Unless they are large enough to cause overload, zero errors do not give rise to any malfunction in the demodulator, simply acting as additive errors which can be measured under zero-signal conditions and subsequently subtracted from the X and Y channel outputs. Consequently, in the model 5105 the output processor includes an output offset facility allowing offsets of up to  $\pm 20\%$  of full-scale to be applied to the X-channel and Y-channel outputs, as reported via the RS232 interface. The offset level can be set using one of two commands, one requiring the user to specify the offset values and the other an auto-offset function.

Since the magnitude and signal phase outputs that can be reported via the RS232 interface are derived by a non-linear operation on the X-channel and Y-channel outputs, it is essential that when using these outputs any X and Y zero errors are first reduced to a small fraction of full scale.

**NOTE:** *The Output Offset function do not affect the CH1 or CH2 analog outputs.*

### 3.2.14 Dynamic Reserve and Output Stability

The 5105/5016 lock-in amplifiers includes gain in three main areas, these being the signal channel ahead of the filters, between the filters and the demodulators, and in the output channels. The first two can be AC coupled, but the output stages have to be DC coupled. DC coupled amplifiers potentially exhibit DC drift with time and temperature, the effect of which increases as the gain increases. Hence it might at first sight appear that it would be best to use high values of AC gain and minimal DC gain. However, if this were done then the instrument would have very low *dynamic reserve*.

The dynamic reserve of a lock-in amplifier is defined as the ratio by which input noise voltages may exceed the full-scale sensitivity value without causing overload. It is usually expressed in decibels:

$$\text{DR(in dB)} = 20 \times \log(\text{DR(as a ratio)})$$

Note that a noise voltage may be random or may be periodic at some fixed frequency; in the latter case it is often referred to as an interfering signal.

Obviously the dynamic reserve value is limited by the full-scale sensitivity setting: for example, a lock-in amplifier could well show a reserve value of 1000 (60 dB) at a full-scale sensitivity setting of 1 mV (implying the capability of handling 1 V noise) but would not be able to maintain this value of reserve at a full-scale sensitivity

setting of 1 V because this would require the capability of handling 1000 V noise.

There are two mechanisms by which dynamic reserve is achieved, demodulator reserve and filter reserve, discussed in the following paragraphs.

#### **Demodulator Reserve**

The demodulator reserve is affected by the total signal channel (AC) gain. If this is high, then the demodulator will overload at lower levels of interfering signal than would be the case with lower gains. Consequently the dynamic reserve will be lower. Hence the maximum reserve is achieved at low levels of signal channel gain.

However at high sensitivity settings, lower values of AC gain require that higher values of DC gain are used to maintain the overall gain. Consequently the instrument exhibits poorer output stability with time and temperature.

#### **Filter Reserve**

One of the functions of the high and low-pass signal-channel filters is to provide dynamic reserve by reducing the amplitude of interfering signals. The success of this operation depends on the frequency of the interfering signal being well outside the pass-band defined by these filters. This is very often the case, because the pass-band occupies only a fraction of the total frequency range; however, when a serious interfering signal does occur in the pass-band, it is sometimes possible to change the frequency of the measurement, for example, by changing the chopper speed in the case of an optical measurement. Note that the action of the filter does not improve the dynamic reserve unless there is amplification in the signal channel following the filter. If such gain is not present, an interfering signal of peak value equal to the overload level at the input of the filter would not cause overload whether attenuated by the filter or not. It follows from these considerations that the greatest improvement in the reserve that the filter can provide is equal to the value of the voltage gain in the signal channel following the signal-channel filter. This value is called the filter reserve.

In many experimental situations where the signal-channel filter is used for reserve improvement, the amount of available filter reserve is not the limiting factor.

Therefore the distribution of the total instrument gain involves two tradeoffs:

- 1) In the signal channel (AC) gain, gain in front of the filter improves the noise while gain after the filter improves the filter reserve.
- 2) Increasing the signal channel (AC) gain and reducing the output (DC) gain improves the output stability but decreases the dynamic reserve.

The model 5105 allows the user to control the distribution of these gains via the dynamic reserve control, which has three settings: high reserve, normal and high stability. The dynamic reserve and output stability available at each setting is shown in table 3-1

Setting	Dynamic Reserve for signals within filter pass-band	Stability
High Reserve	46 dB	500 ppm/°C
Normal	26 dB	100 ppm/°C
High Stability	6 dB	40 ppm/°C

**Table 3-1, Dynamic Reserve and Output Stability**

The high reserve setting may cause increased demodulator noise and signal-channel noise, and reduced output stability. In many measurement situations a dynamic reserve of 26 dB is adequate and the use of the normal setting is recommended.

### 3.2.15 CH1 and CH2 Analog Outputs

The two front-panel connectors **CH1** and **CH2** (or corresponding B401 and B400 pads on the model 5106) give analog voltages proportional to the X and Y channel outputs. The output voltage range is  $\pm 1.2$  V, with  $\pm 1.0$  V corresponding to an input signal of 100% of the full-scale sensitivity setting, and the output impedance is 1 k $\Omega$ .

**NOTE:** *The maximum time constant that can be applied to these outputs is 1 s. Note also that the outputs are not affected by the output offset controls.*

### 3.2.16 Overload Detection

There are two overload detectors in the signal channel, one as part of the signal channel amplifier and the other as part of the signal channel filters. These detect conditions of input overload, which can usually be removed by one or more of the following actions:

- 1) Decreasing the sensitivity setting
- 2) Changing the filter settings to reduce the relative amplitude of interfering signals.
- 3) Changing the Dynamic Reserve to the Normal or High Reserve settings

There are two overload detectors following the demodulators, located at the inputs to the X-channel and Y-channel analog-to-digital converters, which detect output overload conditions. Output overloads can usually be removed by one or more of the following actions:

- 1) Decreasing the sensitivity setting
- 2) Changing the filter settings to reduce the relative amplitude of interfering signals.
- 3) Changing the Dynamic Reserve to the Normal or High Stability settings
- 4) Increasing the time constant setting.

Input and output overload conditions cause the assertion of bit 4 in the status byte which is returned by the ST command, and one or more of bits 3, 4, 5 and 6 in the overload status byte, returned by the N command. Hence a controlling computer program can determine the location of the overload and make the required adjustments to remove it.

### 3.2.17 Analog to Digital Converter

The analog to digital converter (ADC) in the instrument converts the analog signals

at the outputs of the X channel and Y channel output filters to allow them to be read via the computer interfaces. In addition, the digitized signals can also be subjected to further processing by the output processor, as is required for example to derive the signal magnitude and phase.

The ADC is internally triggered asynchronously with respect to the reference. It has an effective resolution of 1 part in 2000, giving an output value of +1000 for an in-phase sinusoidal signal of amplitude equal to the selected full-scale sensitivity setting. Operation remains linear to  $\pm 1200$ , giving 20% over-range capability without overload.

### 3.2.18 Main Microprocessor - General

All functions of the instrument are under the control of a microprocessor which in addition supports the RS232 computer interface. The processor also provides more digital filtering of the X channel and Y channel signals if this is needed in addition to that already performed by the main analog output filters, as well as calculating the vector magnitude and phase of the input signal.

### 3.2.19 Main Microprocessor - Vector Magnitude & Phase

The processor implements the magnitude and signal phase calculation. If the input signal  $V_s(t)$  is a reference frequency sinusoid of constant amplitude, and the output filters are set to a sufficiently long time constant, the demodulator outputs are constant levels  $V_x$  and  $V_y$ . The function  $\sqrt{V_x^2 + V_y^2}$  is dependent only on the amplitude of the required signal  $V_s(t)$  (i.e. it is not dependent on the phase of  $V_s(t)$  with respect to the reference input) and is computed by the output processor and known as the magnitude output. The phase angle between  $V_s(t)$  and the X demodulation function is called the signal phase: this is equal to the angle of the complex quantity  $(V_x + jV_y)$  (where  $j$  is the square root of -1) and is also computed by the processor by means of a fast arc tan algorithm.

The magnitude and signal phase outputs are used in cases where phase is to be measured, or alternatively where the magnitude is to be measured under conditions of uncertain or varying phase.

One case of varying phase is that in which the reference input is not derived from the same source as that which generates the signal, and is therefore not exactly at the same frequency. In this case, if the input signal is a sinusoid of constant amplitude, the X channel and Y channel demodulator outputs show slow sinusoidal variations at the difference frequency, and the magnitude output remains steady.

However, the magnitude output has disadvantages where significant noise is present at the outputs of the demodulator. When the required signal outputs (i.e. the mean values of the demodulator outputs) are less than the noise, the outputs take both positive and negative values but the magnitude algorithm gives only positive values: this effect, sometimes called noise rectification, gives rise to a zero error which in the case of a Gaussian process has a mean value equal to 0.798 times the combined root-mean-square (rms) value of the X and Y demodulator noise. Note that unlike other forms of zero error this is not a constant quantity which can be subtracted from all readings, because when the square root of the sum of the squares of the required

outputs becomes greater than the total rms noise then the error due to this mechanism disappears.

A second type of signal-dependent error in the mean of the magnitude output occurs as a result of the inherent non-linearity of the magnitude formula: this error is always positive and its value, expressed as a fraction of the signal level, is half the ratio of the mean-square value of the noise to the square of the signal.

These considerations lead to the conclusion that when the magnitude output is being used, the time constants of the demodulator should be set to give the required signal/noise ratio at the X channel and Y channel demodulator outputs; improving the signal/noise ratio by averaging the magnitude output itself is not recommended.

For analogous reasons, the magnitude function also shows signal-dependent errors when zero offsets are present in the demodulator. For this reason, it is essential to reduce zero offsets to an insignificant level (usually by the use of the Auto-Offset function) when the magnitude output is to be used.

Note that the majority of signal recovery applications are scalar measurements, where the phase between the required signal and the reference voltage is constant apart from possible phase reversals corresponding to changes in the sign of the quantity being measured. In this situation the lock-in amplifier is used in the normal X-Y mode, with the phase shifter adjusted to maximize the X output and to bring the mean Y output to zero. (Refer to section 3.3.20 for further information on the correct use of the Auto-Phase function for this purpose.)

### 3.2.20 Main Microprocessor - Auto Functions

The microprocessor also controls the instruments two auto-functions, which are control operations executed by means of a single command. These functions allow easier, faster operation in most applications, although dedicated software algorithms may give better results in certain circumstances. During application of the auto-functions, decisions are made on the basis of output readings made at a particular moment. Where this is the case, it is important for the output time constant set by the user to be long enough to reduce the output noise to a sufficiently low level so that valid decisions can be made and that sufficient time is allowed for the output to settle.

The following sections describe these auto-functions. Note that unlike the auto-functions built into some instruments the functions in the 5105 operate only once each time they are selected, rather than remaining active. Hence, for example, the auto-phase function does not cause the instrument to continuously adjust its reference phase control as the input signal phase changes, but rather makes one adjustment which will attempt to match the signal phase at the time the function is called.

#### **Auto-Phase**

In an Auto-Phase operation the value of the signal phase is computed and an appropriate phase shift is then introduced into the reference channel so as to bring the value of the signal phase to zero. The intended result is to null the output of the Y channel while maximizing the output of the X channel.

Any small residual phase can normally be removed by calling Auto-Phase for a

second time after a suitable delay to allow the outputs to settle.

The Auto-Phase facility is normally used with a clean signal which is known to be of stable phase. It usually gives very good results provided that the X channel and Y channel outputs are steady when the procedure is called.

If a zero error is present on the outputs, such as may be caused by unwanted coupling between the reference and signal channel inputs, then the following procedure should be adopted:-

- 1) Remove the source of input signal, without disturbing any of the connections to the signal input which might be picking up interfering signals from the reference channel. In an optical experiment, for example, this could be done by shielding the detector from the source of chopped light.
- 2) Execute an Auto-Offset operation, which will reduce the X channel and Y channel outputs to zero.
- 3) Re-establish the source of input signal. The X channel and Y channel outputs will now indicate the true level of input signal, *at the present reference phase setting*.
- 4) Execute an Auto-Phase operation. This will set the reference phase shifter to the phase angle of the input signal. However, because the offset levels which were applied in step 2 were calculated at the original reference phase setting, they will not now be correct and the instrument will in general display a non-zero Y channel output value.
- 5) Remove the source of input signal again.
- 6) Execute a second Auto-Offset operation, which will reduce the X channel and Y channel outputs to zero at the new reference phase setting.
- 7) Re-establish the source of input signal.

This technique, although apparently complex, is the only way of removing the effect of crosstalk which is not generally in the same phase as the required signal.

#### **Auto-Offset**

In an Auto-Offset operation the X offset and Y offset functions are turned on and are automatically set to the values required to give zero values at both the X and the Y outputs. Any small residual values can normally be removed by calling Auto-Offset for a second time after a suitable delay to allow the outputs to settle.

The primary use of the Auto-Offset is to cancel out zero errors which are usually caused by unwanted coupling or crosstalk between the signal channel and the reference channel, either in the external connections or possibly under some conditions in the instrument itself. Note that if a zero error is present, the Auto-Offset function should be executed before any execution of Auto-Phase.

***NOTE: The offset introduced by the Auto-Offset function does not affect the analog outputs at the CH1 and CH2 connectors.***

This completes the description of the main functional blocks of the instrument.

## 3.3 General

### 3.3.01 Accuracy

When the demodulator is operating under correct conditions, the absolute gain accuracy of the instrument is limited by the analog components in the signal channel and output channels. The resulting typical accuracy is  $\pm 2$  percent of the full-scale sensitivity for output values reported via the RS232 interface and  $\pm 6$  percent of the full-scale sensitivity for the analog CH1 and CH2 outputs.

### 3.3.02 Power-up Defaults

All instrument settings are lost when the unit is switched off. When the instrument is switched on again the controls are set to the following values:

- a) Sensitivity = 1 V rms full-scale
- b) Low-Pass filter = 50 kHz (or 220 kHz in extended frequency range units)
- c) High-Pass filter = 1 Hz
- d) Dynamic Reserve = Normal
- e) Reference Phase =  $0^\circ$
- f) Slope = 12 dB/octave
- g) Time constant = 100 ms
- h) X output offset = 0 and turned off
- i) Y output offset = 0 and turned off
- j) Configuration = Error messages disabled and  $\langle CR \rangle \langle LF \rangle$  output terminator enabled
- h) Delimiter = ASCII 32 (the space character)
- i) Data Request Mode = Inactive

### 4.1 Model 5105 Front Panel

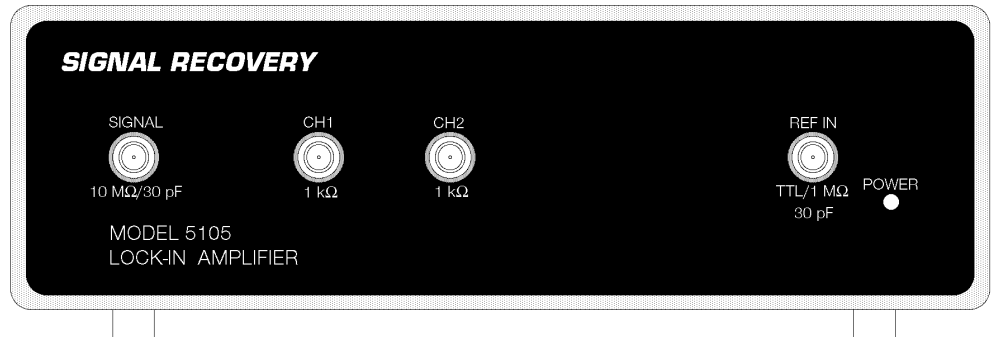

Figure 4-1, Model 5105 Front Panel Layout

The front panel of the Model 5105, shown in figure 4-1 above, has four BNC connectors and an LED indicator, as follows:

#### 4.1.01 SIGNAL connector

This is the signal input connector for use in single-ended and pseudo-differential input modes.

#### 4.1.02 REF IN connector

This is the input connector for the reference signal. The instrument can be configured to accept either a TTL logic signal or any periodic analog signal with approximately 50:50 mark:space ratio at this input by repositioning three internal jumpers. Instruments are supplied with the input configured for an analog reference signal; to change this to the TTL mode please follow the procedure in section 3.2.05.

Although the analog mode is slightly more convenient with reference waveforms of unknown shape, wherever possible use the TTL mode, particularly if the reference signal is asymmetrical.

In analog mode the input impedance at the front-panel **REF IN** connector is 1 MΩ in parallel with 30 pF.

#### 4.1.03 CH1 and CH2 connectors

The signals at these two connectors are analog voltages representing the instrument's X and Y channel outputs respectively. The output voltage range is  $\pm 1.2$  V, with  $\pm 1.0$  V corresponding to an input signal of 100% of the full-scale sensitivity setting, and the output impedance is 1 kΩ.

**NOTE:** *The maximum time constant that can be applied to these outputs is 1 s. Note also that the outputs are not affected by the output offset controls.*

### 4.1.04 POWER LED

This red LED lights when the instrument is powered.

## 4.2 Model 5105 Rear Panel

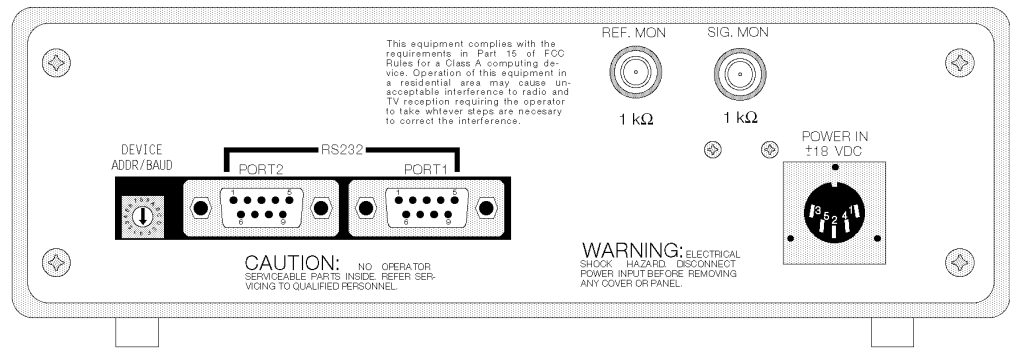

Figure 4-2, Model 5015 Rear Panel Layout

As shown in figure 4-2, the power input socket, two RS232 connectors, two BNC connectors and the RS232 Address switch are mounted on the rear panel of the instrument. Brief descriptions of these are given in the following sections.

### 4.2.01 Power Input Socket

The plug on the output lead of the supplied external power supply module (model PS0108) should be plugged into this 5-pin 180° DIN socket to apply power to the instrument.

### 4.2.02 PORT 1 RS232 Connector

This 9-pin D type RS232 interface connector implements pins 2, 3, 5, 7 and 8 (Receive Data, Transmit Data, Earth Ground, Request to Send and Clear to Send) of a standard 9-pin D type connector DTE interface. To make a connection to a PC-compatible computer, it is normally sufficient to use a three-wire cable connecting Transmit Data to Receive Data, Receive Data to Transmit Data, and Logic Ground to Logic Ground. Appendix D shows the connection diagrams of cables suitable for computers with 9-pin and 25-pin serial connectors. Pinouts for this connector are given in appendix B.

### 4.2.03 PORT 2 RS232 Connector

This connector is used to link other compatible **SIGNAL RECOVERY** equipment together in a "daisy-chain" configuration. Up to an additional 15 units can be connected in this way. Each unit must be set to a unique address (see section 4.2.04). Pinouts for this connector are given in appendix B.

### 4.2.04 DEVICE ADDR/BAUD switch

This rotary switch is used to set the address of the instrument in systems using more than one model 5105 or compatible instrument connected together using an RS232

“daisy chain”. In such systems, each instrument must be set to a unique address.

In normal operation with a single instrument connected to the computer the address setting is unimportant. Note that in spite of its label the switch has no effect on the RS232 baud rate, which is always 4800 baud.

#### 4.2.05 REF. MON Connector

The signal at this connector provides a TTL waveform at the applied reference frequency which can be used to monitor correct reference channel operation. Note that the phase of this waveform with respect to the applied reference is affected by the setting of the reference phase shifter.

#### 4.2.06 SIG. MON Connector

The signal at this connector is the analog signal following the input amplifier and signal channel. It can therefore be used to monitor the effect of the signal channel filters. Because of the operation of the algorithm that distributes the overall gain between the signal channel and the output filters, the gain between the signal input and this connector depends on a number of factors. These include the full-scale sensitivity range, the main signal channel filter setting, the setting of the dynamic reserve control and the setting of the output filter time-constants. This should be taken into account when the using this output to monitor correct lock-in amplifier operation or to implement a stand-alone tuned amplifier.

The signal monitor output is unbuffered, and has an output impedance of 1 k $\Omega$ . As such, it should not be connected to loads of less than 15 k $\Omega$ . Internal noise and switching spikes may be present. The higher the reserve setting, the greater their amplitude will be relative to that of the signal.

### 4.3 Model 5106 PCB Assembly

Connections to and from the model 5106 are made either by soldering directly to areas of copper on the printed circuit board and to pin headers, or by the use of plug-on connectors. Of course, only the required connections need be made, with the unused ones left disconnected.

Figure 4-4 shows the position of the various connection points on the 5106 PCB. Soldering is necessary for the following four connections: **SIGNAL IN**, **CH1**, **CH2** and **REF IN**, but the other two, **REF. MON** and **SIG. MON** may be made using a plug-on pin socket of the form shown in figure 4-3.

***NOTE: Keep the exposed, unscreened, connections as short as possible.***

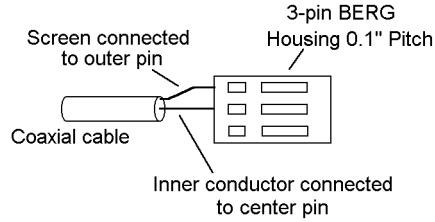

Figure 4-3, BERG Socket Connection Details

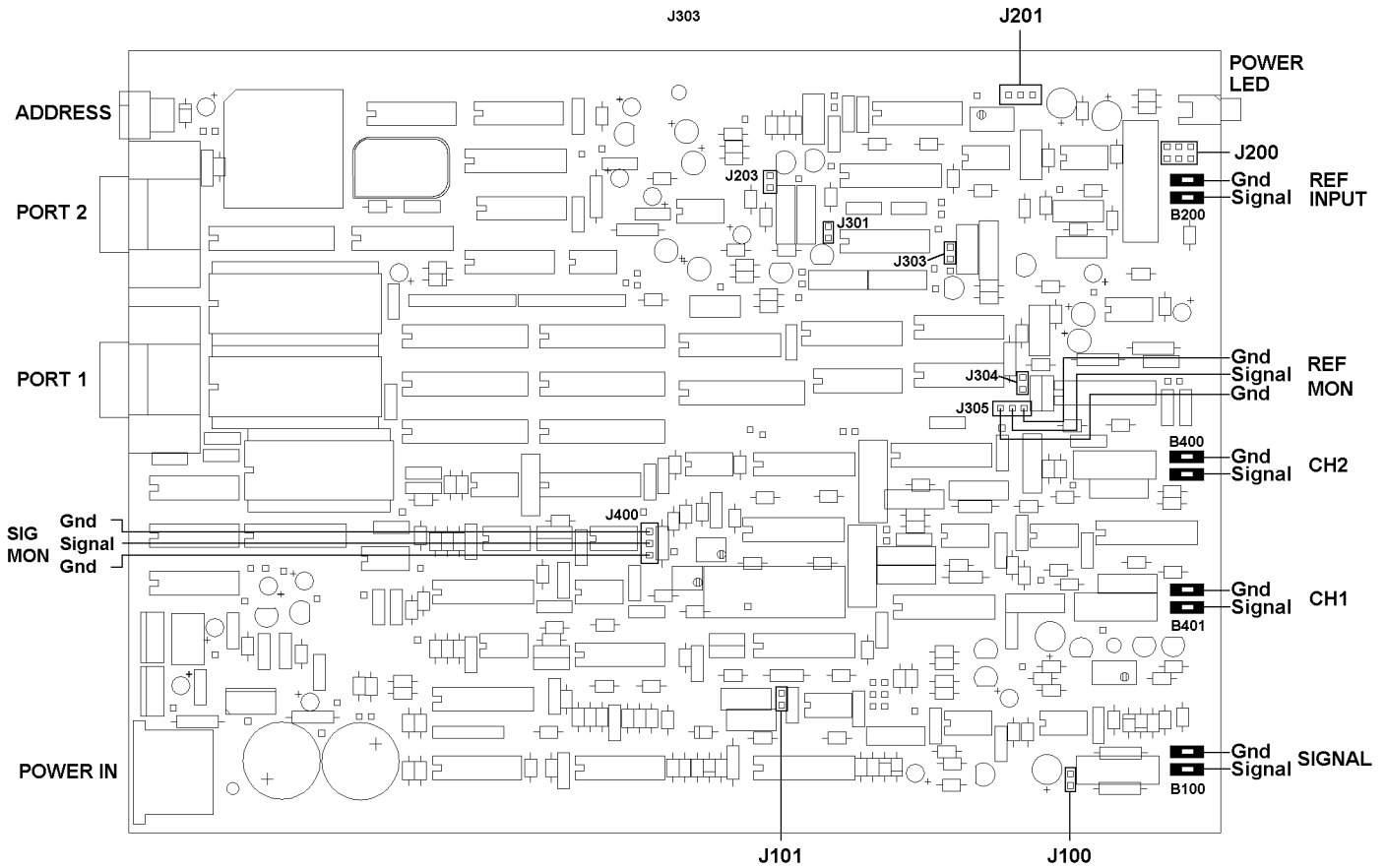

Figure 4-4, Model 5106 PCB Layout - Component Side

The purpose of each of the connection points identified is as follows:

### 4.3.01 SIGNAL connecting point (B100)

This is the signal input connecting point for use in single-ended and pseudo-differential input modes.

### 4.3.02 REF INPUT connecting point (B200)

This is the input connecting point for the reference signal. The instrument can be configured to accept either a TTL logic signal or any periodic analog signal at this input by repositioning three jumpers. Instruments are supplied with the input configured for an analog reference signal; to change this to the TTL mode please

follow the procedure in section 3.2.05.

Although the analog mode is slightly more convenient with reference waveforms of unknown shape, wherever possible use the TTL mode, particularly if the reference signal is asymmetrical.

In analog mode the input impedance at this connecting point is 1 M $\Omega$  in parallel with 30 pF.

### 4.3.03 CH1 and CH2 connecting points (B401 and B400)

The signals at these two connecting points are analog voltages representing the instrument's X and Y channel outputs respectively. The output voltage range is  $\pm 1.2$  V, with  $\pm 1.0$  V corresponding to an input signal of 100% of the full-scale sensitivity setting, and the output impedance is 1 k $\Omega$ .

**NOTE:** *The maximum time constant that can be applied to these outputs is 1 s. Note also that the outputs are not affected by the output offset controls.*

### 4.3.04 POWER LED

This red LED lights when the instrument is powered.

### 4.3.05 Power Input Socket

The model 5016 requires a dual-rail regulated or unregulated DC external power supply of +18 to +21 V @ 300 mA and -18 to -21 V @ 80 mA. This power is applied to the 180° DIN power input socket towards the rear of the board (figure 4-5) by means of a suitable plug.

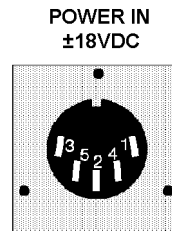

Figure 4-5, Power Input Connector

The pin allocation of this connector is as follows:

Pin	Function
1	No Connection
2	Ground/Earth
3	No Connection
4	-18 V
5	+18 V

The mating plug is SWITCHCRAFT® type 05BL5M or equivalent (**SIGNAL RECOVERY** part number 2102-0171).

#### 4.3.06 PORT 1 RS232 Connector

This 9-pin D type RS232 interface connector implements pins 2, 3, 5, 7 and 8 (Receive Data, Transmit Data, Earth Ground, Request to Send and Clear to Send) of a standard 9-pin D type connector DTE interface. To make a connection to a PC-compatible computer, it is normally sufficient to use a three-wire cable connecting Transmit Data to Receive Data, Receive Data to Transmit Data, and Logic Ground to Logic Ground. Appendix D shows the connection diagrams of cables suitable for computers with 9-pin and 25-pin serial connectors. Pinouts for this connector are given in appendix B.

#### 4.3.07 PORT 2 RS232 Connector

This connector is used to link other compatible **SIGNAL RECOVERY** equipment together in a "daisy-chain" configuration. Up to an additional 15 units can be connected in this way. Each unit must be set to a unique address (see section 4.3.08). Pinouts for this connector are given in appendix B.

#### 4.3.08 DEVICE ADDR/BAUD switch

This rotary switch is used to set the address of the instrument in systems using more than one model 5105 or compatible instrument connected together using an RS232 "daisy chain". In such systems, each instrument must be set to a unique address.

In normal operation with a single instrument connected to the computer the address setting is unimportant. Note that in spite of its label the switch has no effect on the RS232 baud rate, which is always 4800 baud.

#### 4.3.09 REF MON connector (J305)

The signal at this connector provides a TTL waveform at the applied reference frequency which can be used to monitor correct reference channel operation. Note that the phase of this waveform with respect to the applied reference is affected by the setting of the reference phase shifter.

#### 4.3.10 SIG MON Connector (J400)

The signal at this connector is the analog signal following the input amplifier and signal channel. It can therefore be used to monitor the effect of the signal channel filters. Because of the operation of the algorithm that distributes the overall gain between the signal channel and the output filters, the gain between the signal input and this connector depends on a number of factors. These include the full-scale sensitivity range, the main signal channel filter setting, the setting of the dynamic reserve control and the setting of the output filter time-constants. This should be taken into account when the using this output to monitor correct lock-in amplifier operation or to implement a stand-alone tuned amplifier.

The signal monitor output is unbuffered, and has an output impedance of 1 k $\Omega$ . As such, it should not be connected to loads of less than 15 k $\Omega$ . Internal noise and switching spikes may be present. The higher the reserve setting, the greater their amplitude will be relative to that of the signal.

### 5.1 Introduction

The 5105Acquire software is a simple package included with each instrument suitable for operating one or more model 5105 or 5106 lock-in amplifier(s) from a PC running Windows XPSP2, Vista, or later operating systems. It allows all the instrument's controls to be adjusted and the outputs to be displayed via a remote front panel, and as such gives the same ease of operation as when using a traditional lock-in amplifier with manually operated front panel controls.

The software does not include any facility for recording instrument outputs as a function of time, but users who wish to do this can purchase the full Acquire software as an optional extra. A free demonstration version of this software is available from our website at [www.signalrecovery.com](http://www.signalrecovery.com)

### 5.2 Installation

To install the 5105Acquire software, simply insert the supplied Program Disk into an appropriate disk drive and using the Run menu item, or otherwise, locate and run the Setup.exe program located on it. This will install the 5105Acquire software on the computer's hard disk.

### 5.3 Operation

#### 5.3.01 Getting Started

The software can be started by selecting the SIGNAL RECOVERY 5105Acquire item from the Start Programs menu, or by using Explorer to locate the program file 5105Acquire.exe and double clicking on it.

On the first occasion that the program is run after installation the Instrument connections dialog, shown in figure 5-1, is displayed.

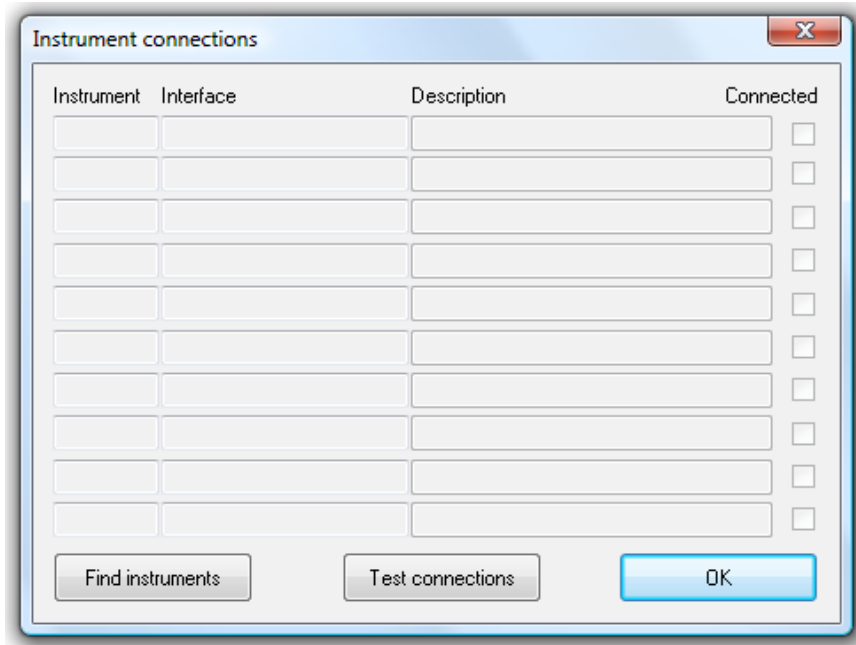

**Figure 5-1, Instrument Connections Dialog  
- No Instruments Connected**

Clicking the **Find Instruments** button starts a search for compatible connected instruments, during which the program systematically addresses each available communications port. If there are several model 5105/5106's connected via a "daisy chain" then click Yes when prompted if this method of connection is being used; otherwise, click No for a faster search. During this process the Searching for instruments... dialog is displayed, shown in figure 5-2.

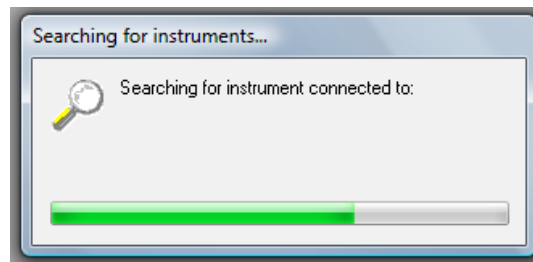

**Figure 5-2, Searching for Instruments Dialog**

*Note: You may safely ignore any warning about not being able to locate a GPIB interface board since the models 5105 and 5106 can only be controlled via the RS232 interface.*

When an instrument of a type supported by the software responds, the details of the model number, communications settings and other information are stored. Once all ports have been searched, the Instrument connections dialog is updated, as shown in figure 5-3, where a model 5105 at serial port COM1 has been found.

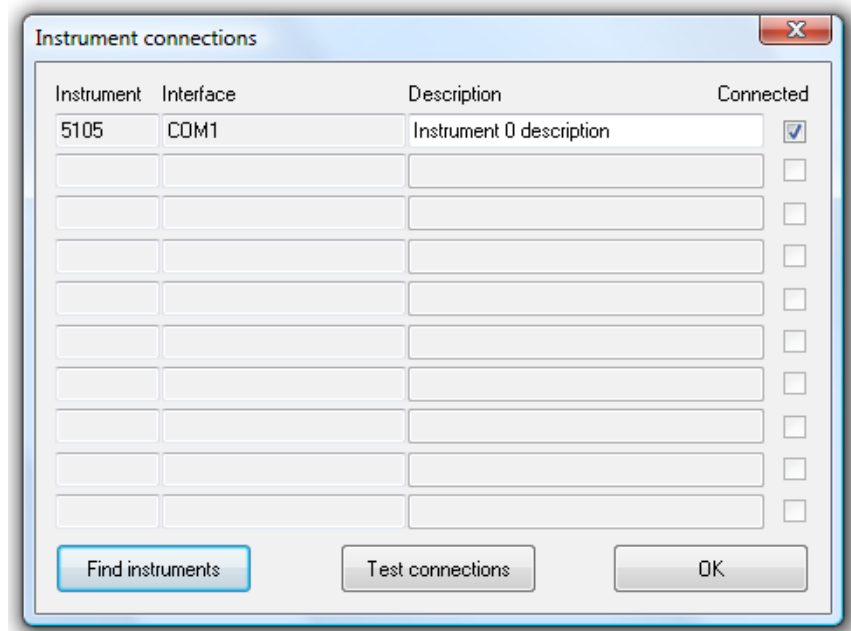

**Figure 5-3, Instrument Connections Dialog  
- Model 5105 Connected to Serial Port COM1**

If desired, the default instrument descriptions can be changed so that it is meaningful in your experiment. For example, descriptions such as "photocurrent", "sample voltage" or "temperature" could be used.

Clicking the **OK** button closes the dialog and returns to the main program window.

On second and subsequent occasions the program is run, it first verifies that the instrument(s) recorded in the Instrument connections dialog are present, and if not displays a warning message, allowing the error to be fixed

The Instrument connections dialog can also be activated at any time by clicking the  toolbar button or selecting the **Hardware, Instrument connections...** menu item.

The "Connected" check boxes next to each description indicate whether the specified instrument is actually present. For example, in the case above where a model 5105 was detected the first time the program was run, if the software were started again but without having turned on the power to it then a warning message would be displayed. On displaying the Instrument connections dialog the relevant box would be unchecked, giving a quick indication of where the problem lay. Having turned on the 5105, clicking **Test Connections** would re-establish connection and check the corresponding Connected box.

Clicking the **Find Instruments** button clears the saved information and descriptions, and starts a new search for connected instruments.

After the program has verified that the instrument(s) are connected, the main window is displayed, which has a layout similar to that shown in figure 5-4.

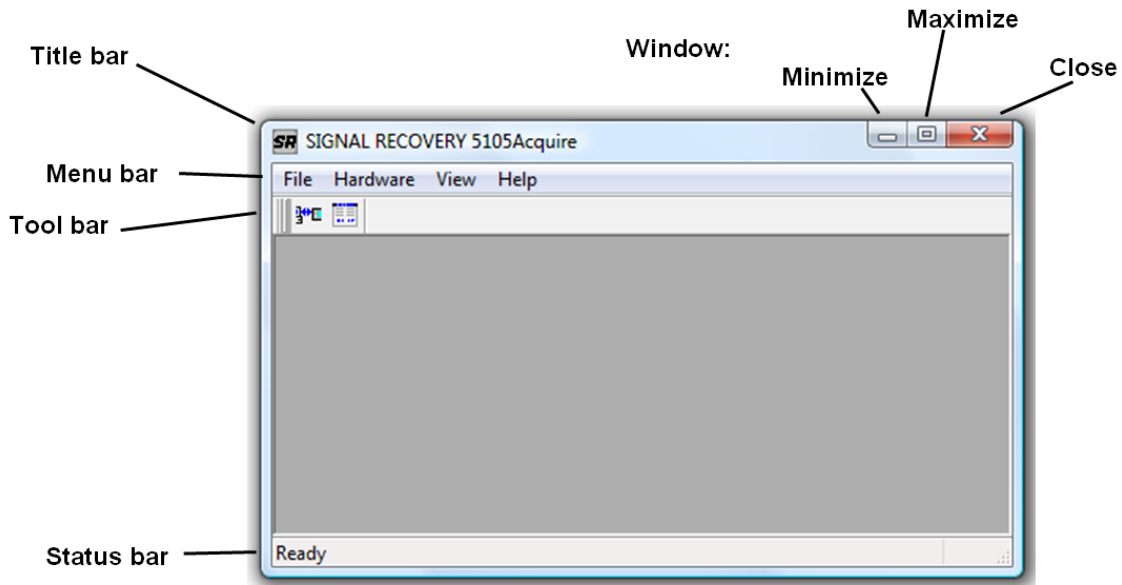

Figure 5-4, 5105Acquire Main Display

### 5.3.02 Remote Front Panel - Main Display

Once the main window is displayed, selecting the **Hardware, Control 5105 xxxx** or **Control 5106 xxxx** menu item (where xxxx is the instrument description), opens a remote front panel for the lock-in amplifier. This takes the form of a tabbed dialog box, similar to that shown in figure 5-3, which allows the instrument controls to be adjusted and the measured outputs to be displayed.

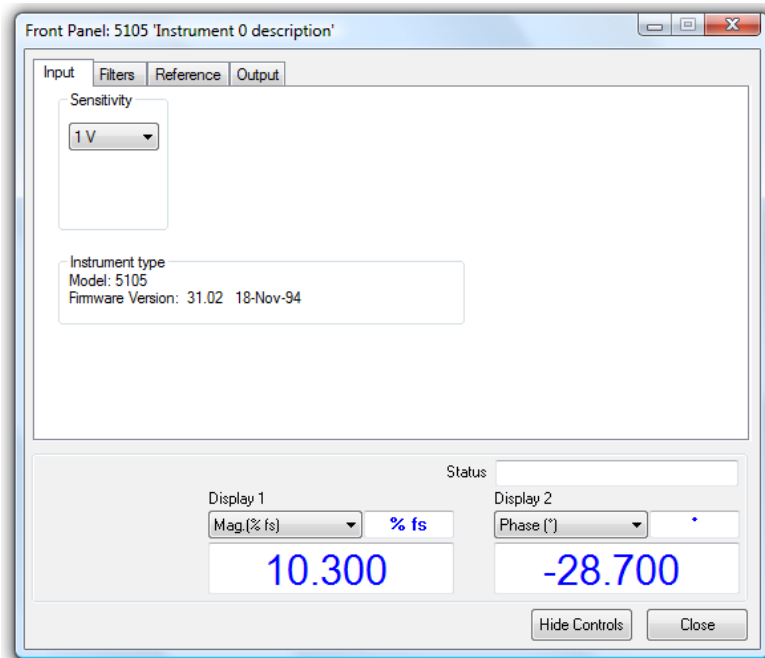

Figure 5-5, 5105Acquire Software Remote Front Panel

The **Display 1** and **Display 2** dropdown selectors are used to specify which outputs appear on the large digital meters. Values expressed as a percentage are with respect to the set full-scale sensitivity, so that for example the unit is set to 100 mV and a 50 mV in-phase signal were applied within the pass-band defined by the signal filters then a meter set to **X %** would read near to 50%, while one set to **X V** would read 50 mV. The **Mag** settings display the vector magnitude of the input signal, and the **Phase** setting gives the signal phase in degrees. Finally the measured reference frequency can also be displayed.

The output readings are updated nominally once per second. Conditions such as overload and unlock are reported in the **Status** box above and the right of the **Display 2** digital meter.

### 5.3.03 Remote Front Panel - Input Tab

The input tab, shown in figure 5-6, is used to adjust the full-scale sensitivity. It also reports the model number and firmware version of the connected instrument.

The instrument does not support certain combinations of settings, e.g. it is not possible to use sensitivities of 100  $\mu$ V or greater at time constants of 10 ms or shorter. If an attempt is made to set controls to such illegal ranges then an information dialog box is displayed, similar to that shown in figure 5-7.

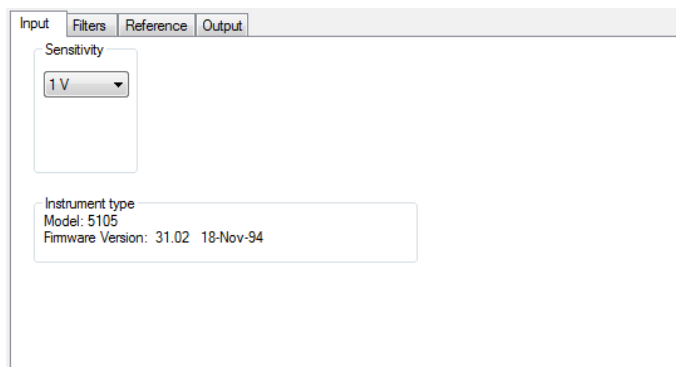

Figure 5-6, 5106Acquire Software Input Tab

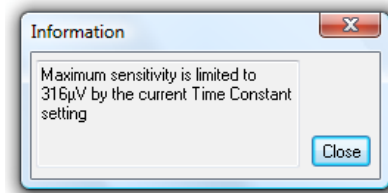

Figure 5-7, Information Box

### 5.3.04 Remote Front Panel - Filters Tab

The filters tab, shown in figure 5-8, is used to configure the signal channel filters.

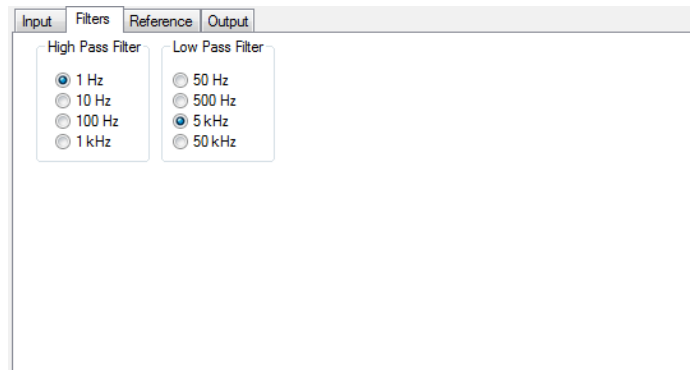

Figure 5-8, 5105Acquire Software Filters Tab

### 5.3.05 Remote Front Panel - Reference Tab

The reference tab, shown in figure 5-9, is used to adjust the reference phase and to initiate an auto-phase operation. It also shows the frequency of the applied reference, as measured using the internal frequency counter.

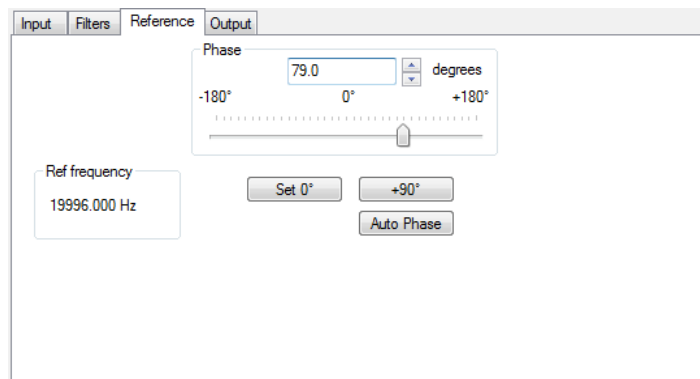
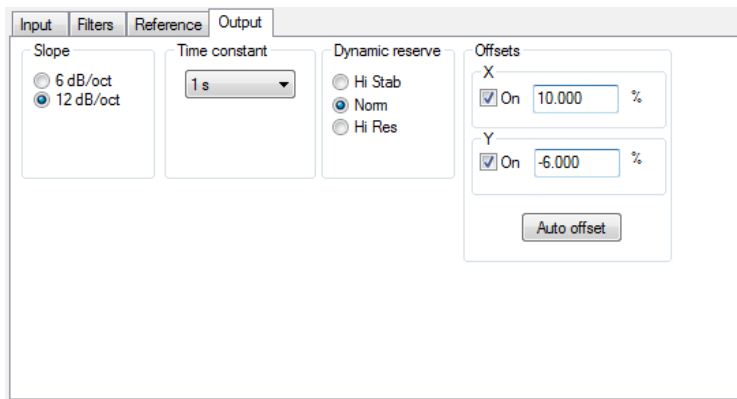

Figure 5-9, 5105Acquire Software Reference Tab

### 5.3.06 Remote Front Panel - Output Tab

The output tab, shown in figure 5-10, has controls for the output filter slope, output filter time constant, dynamic reserve and output offset. It is also used to initiate an auto-offset operation



**Figure 5-10, 5105Acquire Software Output Tab**

The other menu items in the software operate in the same way as in many other Windows applications.



### 6.1 Introduction

The model 5105 uses an RS232 interface port to allow it to be completely controlled from a remote computer. All the instrument's controls may be operated, and all the outputs read, via this interface.

This chapter describes how the interface operates and the command set used to control the instrument. As in chapter 3, the model number 5105 can be taken to include the model 5106, except where stated otherwise.

### 6.2 RS232 Operation

#### 6.2.01 Introduction

Control of the lock-in amplifier from a computer is accomplished by means of communications over the RS232 interface. The communication activity consists of the computer sending commands to the lock-in amplifier, and the lock-in amplifier responding, either by sending back some data or by changing the setting of one of its controls. The commands and responses are encoded in standard 7-bit ASCII format, with one or more additional bits as required by the interface (see below).

Although the interface is primarily intended to enable the lock-in amplifier to be operated by a computer program specially written for an application, it can also be used in the direct, or terminal, mode. In this mode the user enters commands on a keyboard and reads the results on a video screen.

The simplest way to establish the terminal mode is to connect a standard terminal, or a terminal emulator, to the RS232 port. A terminal emulator is a computer running special-purpose software that makes it act as a terminal. In the default (power-up) state of the port, the lock-in amplifier sends a convenient prompt character when it is ready to receive a command, and echoes each character that is received.

Microsoft Windows XP includes a program called HyperTerminal, usually in the Accessories group, which may be used as a terminal emulator. The same program is widely available to download for use with Windows Vista. On the other hand, a simple terminal program with minimal facilities can be written in a few lines of BASIC code (see appendix C.1).

#### 6.2.02 RS232 Interface - General Features

The RS232 interface in the model 5105 is implemented with three wires; one carries digital transmissions from the computer to the lock-in amplifier, the second carries digital transmissions from the lock-in amplifier to the computer and the third is the Logic Ground to which both signals are referred. The logic levels are  $\pm 12$  V referred to Logic Ground, and the connection may be a standard RS232 cable in conjunction with a null modem or alternatively may be made up from low-cost general purpose cable. The pinout of the RS232 connectors are shown in appendix B and cable

diagrams suitable for coupling the instrument to a computer are shown in appendix D.

A single RS232 transmission consists of a start bit followed by 7 or 8 data bits, an optional parity bit, and 1 stop bit. The rate of data transfer depends on the number of bits per second sent over the interface, usually called the baud rate. In the model 5105 the baud rate is fixed at 4,800.

Mostly for historical reasons, there are a very large number of different ways in which RS232 communications can be implemented. Apart from the baud rate options, there are choices of data word length (7 or 8 bits), parity check operation (even, odd or none), and number of stop bits (1 or 2). For the sake of simplicity the communications settings are fixed in the model 5105 at 4,800 baud, No Parity, Eight Data Bits, One Stop Bit and with the ASCII carriage return character (<CR>, ASCII decimal 10) as the input terminator.

**NOTE:** *In order to achieve satisfactory operation, the RS232 settings in the terminal or computer must be set to these values.*

### 6.2.03 Auxiliary RS232 Interface

The auxiliary RS232 interface allows up to fifteen model 5105s or other compatible instruments to be connected to one serial port on the computer. The first lock-in amplifier is connected to the computer in the usual way. Additional lock-in amplifiers are connected in a daisy-chain fashion using null-modem cables, the **PORT 2** port of the first to the **PORT 1** port of the second, the **PORT 2** port of the second to the **PORT 1** port of the third, etc. The address of each lock-in amplifier must be then be set to a different value using the rear-panel rotary **DEVICE ADDR/BAUD** switch before any communication takes place. At power-up the RS232 port of each lock-in amplifier is fully active irrespective of its address. Since this means that all lock-in amplifiers in the daisy-chain are active on power-up, the first command must be \n where n is the address of one of the lock-in amplifiers. This will deselect all but the addressed lock-in amplifier. When it is required to communicate with another lock-in amplifier, send a new \n command using the relevant address.

**NOTE:** *When programming in C remember that in order to send the character \n in a string it is necessary to type in \\.*

### 6.2.04 Handshaking and Echoes

A handshake is a method of ensuring that the transmitter does not send a byte until the receiver is ready to receive it, and, in the case of a parallel interface, that the receiver reads the data lines only when they contain a valid byte.

In the RS232 standard there are several control lines called handshake lines (RTS, DTR outputs and CTS, DSR, DCD inputs) in addition to the data lines (TD output and RD input). However, these lines are not capable of implementing the handshaking function required by the model 5105 on a byte-by-byte basis and are not connected in the model 5105 apart from the RTS and DTR outputs which are constantly asserted.

Note that some computer applications require one or more of the computer's RS232

handshake lines to be asserted. If this is the case, and if the requirement cannot be changed by the use of a software switch, the cable may be used in conjunction with a null modem. A null modem is an adapter which connects TD on each side through to RD on the other side, and asserts CTS, DSR, and DCD on each side when RTS and DTR are asserted on the other side.

With most modern software there is no need to assert any RS232 handshake lines and a simple three-wire connection can be used. The actual handshake function is performed by means of bytes transmitted over the interface.

The more critical handshake is the one controlling the transfer of a command from the computer to the lock-in amplifier, because the computer typically operates much faster than the lock-in amplifier and bytes can easily be lost if the command is sent from a program. (Note that because of the limited speed of human typing, there is no problem in the terminal mode.) Therefore an echo handshake is used, which works in the following way:

After receiving each byte, the lock-in amplifier sends back an echo, that is a byte which is a copy of the one that it has just received, to indicate that it is ready to receive the next byte. Correspondingly, the computer does not send the next byte until it has read the echo of the previous one. Usually the computer makes a comparison of each byte with its echo, and this constitutes a useful check on the validity of the communications.

The program RSCOM2.BAS in section C.2 illustrates the use of the echo handshake.

In some cases, timing errors may occur in the communication of the lock-in amplifier's responses to the computer. The 5105 provides for this with the *data request mode* entered by means of the DRQMODE 1 command. In this mode the lock-in amplifier will not send any response character unless the computer has previously sent the data request byte, which is a pound (hash) symbol, # (ASCII character 35). Each data request byte sent by the computer causes one response byte to be sent by the lock-in amplifier.

### 6.2.05 Terminators

In order for communications to be successfully established between the lock-in amplifier and the computer, it is essential that each transmission, i.e. command or command response, is terminated in a way which is recognizable by the computer and the lock-in amplifier as signifying the end of that transmission.

The lock-in amplifier requires a <CR> as an input command terminator, and sends out <CR><LF> as an output response terminator except when the command CONFIG 128 has been sent, in which case there is no output terminator. The default (power-up) state is for the output terminator to be appended.

## 6.2.06 Command Format

The simple commands listed in section 6.3 have one of six forms:

CMDNAME terminator  
CMDNAME n terminator  
CMDNAME [n] terminator  
CMDNAME [n<sub>1</sub> n<sub>2</sub>] terminator  
CMDNAME [n<sub>1</sub> [n<sub>2</sub>]] terminator  
CMDNAME n<sub>1</sub> n<sub>2</sub> terminator

where CMDNAME is an alphanumeric string that defines the command, and n, n<sub>1</sub>, n<sub>2</sub> are parameters separated by spaces. When n is not enclosed in square brackets it must be supplied. [n] means that n is optional. [n<sub>1</sub> [n<sub>2</sub>]] means that n<sub>1</sub> is optional and if present may optionally be followed by n<sub>2</sub>. Upper-case and lower-case characters are equivalent. Terminator bytes are defined in section 6.2.05.

**NOTE:** *Where the command syntax includes optional parameters and the command is sent without the optional parameters, the response consists of a transmission of the present values of the parameter(s).*

Any response transmission consists of one or more numbers followed by a response terminator. Where the response consists of two or more numbers in succession, they are separated by a delimiter (section 6.3.07).

## 6.2.07 Delimiters

Any response transmissions consist of one or two numbers followed by a response terminator. Where the response of the lock-in amplifier consists of two numbers in succession, they are separated by a byte called a delimiter. This delimiter can be any printing ASCII character and is selected by the use of the DD command. The default (power-up) delimiter character is the space character (ASCII 32).

## 6.2.08 Compound Commands

A compound command consists of two or more simple commands separated by semicolons (ASCII 59) and terminated by a single command terminator. If any of the responses involve data transmissions, each one is followed by an output terminator.

## 6.2.09 Status Byte, Prompts and Overload Byte

In RS232 communications, comparatively rapid access to the status of the instrument is provided by the prompt character which is sent by the lock-in amplifier after each command, unless the user has chosen to suppress it. The prompt takes one of two forms. If the command contained an error, either in syntax or by a command parameter being out of range, or alternatively if an overload or reference unlock is currently being reported, the prompt is ? (ASCII 63). Otherwise the prompt is \* (ASCII 42).

When the ? prompt is received by the computer, the ST command may be issued in order to discover which type of fault exists so that appropriate action can be taken.

The prompts are a rapid way of checking on the instrument status and enable a convenient keyboard control system to be set up simply by attaching a standard terminal, or a simple computer-based terminal emulator, to the RS232 port.

Because of the limited number of bits in the status byte, it can indicate that an overload exists but cannot give more detail. An auxiliary byte, the overload byte returned by the N command, gives details of the location of the overload.

A summary of the bit assignments in the status byte and the overload byte is given below.

	Status Byte	Overload Byte
bit 0	command complete	not used
bit 1	invalid command	not used
bit 2	command parameter error	not used
bit 3	reference unlock	CH1 (X-channel) output overload
bit 4	overload	CH2 (Y-channel) output overload
bit 5	not used	PSD overload
bit 6	not used	signal channel overload
bit 7	not used	reference unlock

## 6.3 Command Descriptions

This section lists the commands in logical groups, so that, for example, all commands associated with setting controls affecting the signal channel are shown together. Appendix E gives the same list of commands but in alphabetical order.

### 6.4.01 Signal Channel

SEN [n] Full-scale sensitivity control

The value of n sets the full-scale sensitivity according to the following table:

n	full-scale sensitivity
0	10 $\mu$ V
1	31.6 $\mu$ V
2	100 $\mu$ V
3	316 $\mu$ V
4	1 mV
5	3.16 mV
6	10 mV
7	31.6 mV
8	100 mV
9	316 mV
10	1 V

**NOTE:** If the Sensitivity setting is 10  $\mu$ V, 31.6  $\mu$ V or 100  $\mu$ V ( $0 \leq n \leq 2$ ) then setting the Time Constant to 10 ms or shorter will cause the Sensitivity setting to change to 316  $\mu$ V ( $n = 3$ )

LPF [n] Signal channel low-pass filter control

In standard units, which operate to 20 kHz, the LPF command sets the frequency of

the low-pass signal channel filter mode according to the following table:

n	Selection
0	50 Hz
1	500 Hz
2	5 kHz
3	50 kHz

However, units supplied calibrated to operate at spot frequencies in the range 20 kHz to 100 kHz have modified filter settings, as follows:

n	Selection
0	220 Hz
1	2.2 kHz
2	22 kHz
3	220 kHz

HPF [n]                      Signal channel high-pass filter control

The HPF command sets the frequency of the low-pass signal channel filter mode according to the following table:

n	Selection
0	1 Hz
1	10 Hz
2	100 Hz
3	1 kHz

### 6.4.02 Reference Channel

P [n<sub>1</sub> n<sub>2</sub>]                      Reference phase control

The P command sets the reference phase according to the following table:

n <sub>1</sub>	Quadrant	Phase Range
0	1	0° to 90°
1	2	90° to 180°
2	3	180° to 270°
3	4	270° to 360°

n<sub>2</sub> is in units of 0.1° and hence takes values in the range 0 to 1000 corresponding to phase shifts of 0 to 100°

For example, to set the reference phase to 45° send the command P 0 450

AQN                              Auto-Phase (auto quadrature null)

The instrument adjusts the reference phase to maximize the X channel output and minimize the Y channel output signals.

FRQ                              Reference frequency meter

The FRQ command causes the lock-in amplifier to respond with 0 if the reference channel is unlocked, or with the reference input frequency, expressed in millihertz, if it is locked.

### 6.4.03 Signal Channel Output Filters

XDB [n] Output low-pass filter slope (roll-off) control

The value of n sets the slope of the output filters according to the following table:

n	Slope
0	6 dB/octave
1	12 dB/octave

TC [n]

XTC [n] Filter time constant control

The value of n sets the time constant of the output according to the following table:

n	time constant
0	300 $\mu$ s
1	1 ms
2	3 ms
3	10 ms
4	30 ms
5	100 ms
6	300 ms
7	1 s
8	3 s
9	10 s

The time constants and outputs available depend on the full-scale sensitivity setting, as follows:

**Time Constant = 300  $\mu$ s to 10 ms**

Analog and Digital outputs but only with Sensitivity settings in range of 300  $\mu$ V to 1 V. This is known as the FAST mode.

**Time Constant = 30 m to 1 s**

Analog and Digital outputs at all Sensitivity settings.

**Time Constant = 3 s and 10 s**

Digital outputs only at all Sensitivity settings.

### 6.4.04 Signal Channel Output Amplifiers

DR [n] Dynamic Reserve control

The value of n sets the dynamic reserve mode according to the following table:

n	Mode
0	High Stability
1	Normal
2	High Reserve

OFEN [n] Output offset status control

The value of n sets the offset status of both the X and Y channel output offsets according to the following table:

- n Selection
- 0 Disables offsets
- 1 Enables offsets

XOF [ $n_1$  [ $n_2$ ]] X channel output offset control  
The value of  $n_1$  sets the status of the X channel output offset facility according to the following table:

- $n_1$  Selection
- 0 Disables X offset
- 1 Enables X offset facility if OFEN = 1

The range of  $n_2$  is  $\pm 200$  corresponding to  $\pm 20\%$  full-scale.

**NOTE: Offsets apply only to the digital outputs and not to the CH1 or CH2 analog outputs.**

YOF [ $n_1$  [ $n_2$ ]] Y channel output offset control  
The value of  $n_1$  sets the status of the Y channel output offset facility according to the following table:

- $n_1$  Selection
- 0 Disables Y offset facility
- 1 Enables Y offset facility if OFEN = 1

The range of  $n_2$  is  $\pm 200$  corresponding to  $\pm 20\%$  full-scale.

**NOTE: Offsets apply only to the digital outputs and not to the CH1 or CH2 analog outputs.**

AXO Auto-Offset

This command turns on the X and Y channel output offsets, and assuming that there is sufficient range, are set to levels giving zero X and Y channel outputs. Any changes in the input signal then appear as changes about zero in the outputs.

**NOTE: Offsets apply only to the digital outputs and not to the CH1 or CH2 analog outputs.**

### 6.4.05 Instrument Outputs

X X channel output

The X command causes the lock-in amplifier to respond with the X demodulator output in the range  $\pm 1200$ , full-scale being  $\pm 1000$ .

XY X, Y channel outputs

The XY command causes the lock-in amplifier to respond with the X and Y demodulator outputs, separated by the character defined by the DD command, in the range  $\pm 1200$ , full-scale being  $\pm 1000$ .

MAG Magnitude

The MAG command causes the lock-in amplifier to respond with the magnitude value in the range 0 to +1200, full-scale being +1200.



OUTPLOT 1 2 might give the following output with a new line produced every two seconds.

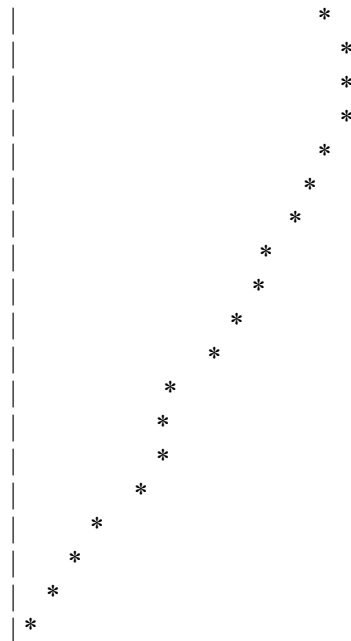

Where:

- \* represents the MAG output,
- | represents the "0" position,
- and the right edge of the screen is full-scale.

### 6.4.06 Computer Interface

CONFIG [n]            Configure error message status

The value of n sets the error message status and the terminator sent with each transmission from the instrument to the computer according to the following table:

n	Error Message Status	Output Terminator Status
0	Error messages disabled	Append <CR><LF>
4	Error messages enabled	Append <CR><LF>
128	Error messages disabled	No terminator

Other values of n are invalid.

\ n                    Address command

When the model 5105 or 5106 is daisy-chained with other compatible instruments this command will change which instrument is addressed. All daisy-chained instruments receive commands but only the currently addressed instrument will implement or respond to the commands. The exception is the \ n command. If n matches the address set from the rear panel switch the unit will switch into addressed mode. If n does not match this address instrument will switch into unaddressed mode. Note that the \ n command does not change the address of an instrument but rather which instrument is addressed.

**NOTE: All instruments must have a unique address.**

- CADDR**                    Return current address  
The CADDR returns the setting of the RS232 address switch and hence the address of the currently selected unit.
- DD [n]**                    Define delimiter control  
The value of n, which can be set to 13 or from 32 to 125, determines the ASCII value of the character sent by the lock-in amplifier to separate two numeric values in a two-value response, such as that generated by the XY (magnitude and phase) command. The default (power-up value) is 32, corresponding to a space character.
- DRQMODE [n]**    Data request mode control  
The value of parameter n sets or reads the data request mode status in accordance with the following table:
- |   |                          |
|---|--------------------------|
| n | significance             |
| 0 | Normal operation         |
| 1 | Data Request Mode active |
- ST**                            Report status byte  
Causes the lock-in amplifier to respond with the status byte, an integer between 0 and 31, which is the decimal equivalent of a binary number with the following bit-significance:
- |       |                         |
|-------|-------------------------|
| Bit 0 | Command complete        |
| Bit 1 | Invalid command         |
| Bit 2 | Command parameter error |
| Bit 3 | Reference unlock        |
| Bit 4 | Overload                |
- N**                              Report overload byte  
Causes the lock-in amplifier to respond with the overload byte, an integer between 0 and 255, which is the decimal equivalent of a binary number with the following bit-significance:
- |       |  |
|-------|--|
| Bit 0 | not used                                     |
| Bit 1 | not used                                     |
| Bit 2 | not used                                     |
| Bit 3 | CH1 (X-channel) output overload (> ±120 %FS) |
| Bit 4 | CH2 (Y-channel) output overload (> ±120 %FS) |
| Bit 5 | Phase Sensitive Detector(s) overload         |
| Bit 6 | Signal Channel Overload                      |
| Bit 7 | Reference unlock                             |
- HELP**                        Display command list  
The HELP command displays a list on an attached terminal of the commands that the instrument responds to. It is of most use when operating the unit from such a terminal and is not normally used when controlling it from a program.

### 6.4.07 Instrument Identification

- ID**                            Identification  
Causes the lock-in amplifier to respond with its model number, either 5105 or 5106.

VER	Report firmware version Causes the lock-in amplifier to respond with the firmware version number. This gives a two-line response which the controlling program must be able to accept.
-----	---

## 6.5 Programming Examples

### 6.5.01 Introduction

This section gives some examples of the commands that need to be sent to the lock-in amplifier for typical experimental situations.

### 6.5.02 Converting Output Values to Voltages

Instrument commands which report output values do so with a number which represents the output as a proportion of the present full-scale sensitivity, where a response of “+1000” represents 100% of full-scale. If it is desired to know what this represents in terms volts at the input, then the following procedure needs to be adopted:

- 1) Issue a SEN command to determine the present sensitivity setting. Let the response from this command be *senrange*code.
- 2) Determine the full-scale sensitivity range expressed in volts, *senrange*, by the use of a look-up table, using the values given in the description of the SEN command in section 6.4.01
- 3) Issue the command to report the required output. For example, if the X channel output is required, issue the XY command and process the first of the two responses. This will be a value between -1200 and +1200, corresponding to  $\pm 120.00\%$  of the full-scale sensitivity. Let the reported value be *outputuncal*
- 4) The output can now be expressed in terms of volts as *outputcalib* by the use of the following equations:-

$$\text{outputcalib} = \text{outputuncal} \times \text{senrange} \times 10^{-3} \text{ Volts}$$

### 6.5.03 Basic Signal Recovery

In a typical simple experiment, the computer is used to set the instrument controls and then to record the chosen outputs, perhaps as a function of time. The commands to achieve this would therefore be similar to the following sequence:

SEN 4	Set sensitivity to 1 mV full-scale
LPF 2	Set signal channel low pass filter to 5 kHz
HPF 2	Set signal channel high pass filter to 100 Hz (signal is at a reference frequency of 2 kHz)
TC 5	Set time constant to 100 ms
DR 1	Set Normal dynamic reserve
AQN	Perform auto-phase

Then the outputs could be read as follows:

XY	Reads X and Y outputs
MAG	Reads Magnitude
PHA	Reads Phase
FRQ	Reads reference frequency in millihertz

The controlling program would send a new output command each time a new reading were required. Note that a good “rule of thumb” is to wait for a period of five time-constants after the input signal has changed before recording a new value. Hence in a scanning type experiment, the program should issue the commands to whatever equipment causes the input signal to the lock-in amplifier to change, wait for five time-constants, and then record the required output.



# Specifications

## General

Dual-phase analog lock-in amplifier operating over a reference frequency range of 5 Hz to 20 kHz, but also available calibrated for use at one user-specified spot frequency in the range 20 kHz to 100 kHz

The model 5105 is a complete tested module and the model 5106 is tested PCB assembly. Both units share common specifications.

## Measurement Modes

The instrument can simultaneously measure these outputs:

X	In-phase
Y	Quadrature
R	Magnitude
$\theta$	Phase Angle

## Signal Channel Input

Modes	Single-ended or pseudo-differential
Grounding	Input signal ground can be grounded or floated via 1 k $\Omega$ to ground using internal jumper
Full-scale Sensitivity	10 $\mu$ V to 1 V in a 1-3.16-10 sequence (10 dB steps)
Max. Dynamic Reserve	> 80 dB
Impedance	10 M $\Omega$ // 30 pF
Maximum Safe Input	20 V pk-pk
Voltage Noise	< 30 nV/ $\sqrt$ Hz @ 1 kHz
C.M.R.R.	> 40 dB @ 1 kHz
Frequency Response	5 Hz to 100 kHz
Gain Accuracy	2% typical for digital outputs; 6% typical for analog outputs
Gain Stability	200 ppm/ $^{\circ}$ C typical

## Signal Channel Filters

High-pass Signal Channel Filter	
-3 dB frequency	1 Hz, 10 Hz, 100 Hz or 1 kHz
Low-pass Signal Channel Filter	
-3 dB frequency	50 Hz, 500 Hz, 5 kHz or 50 kHz or, by jumper selection, 220 Hz, 2.2 kHz, 22 kHz or 220 kHz
Frequency Accuracy	$\pm$ 10%

## Reference Channel

Mode	TTL or Analog input
Frequency Range	5 Hz to 20 kHz or spot frequencies to 100 kHz
Analog Impedance	1 M $\Omega$ // 30 pF
Reference harmonic	F only
Phase Set Resolution	0.1° increments
Phase Set Accuracy	$\pm 1^\circ$
Phase Noise	$\leq 0.015^\circ$ rms @ 1 kHz, 100 ms, 12 dB TC $\leq 0.007^\circ$ rms @ 10 kHz, 100 ms, 12 dB TC
Phase Drift	$< 0.05^\circ/\text{C}$
Orthogonality	$\pm 1^\circ$
Acquisition Time	1 s + 2 cycles max

## Demodulator and Output Processing

Mode	Squarewave switching demodulator + HP/LP filters
------	--

Zero stability/Dynamic Reserve

Setting	Dynamic Reserve for signals within filter pass-band	Stability
High Reserve	46 dB	500 ppm/°C
Normal	26 dB	100 ppm/°C
High Stability	6 dB	40 ppm/°C

## Output Filters

Time Constants	
Analog and Digital Outputs	
Fast Mode	300 $\mu$ s, 1 ms, 3 ms or 10 ms (316 $\mu$ V to 1 V FS sensitivity)
Normal Mode	30 ms, 100 ms, 300 ms or 1 s
Digital Outputs only	3 s and 10 s
Accuracy	$\pm 10\%$
Slope	6 dB/octave or 12 dB/octave
Offsets	$\pm 20\%$ full-scale, X and/or Y

## Outputs

Main Analog (X and Y) Outputs	
Amplitude	$\pm 1$ V FS
Impedance	1 k $\Omega$
Signal Monitor	10 V pk-pk maximum
Reference Output	
Waveform	0 to 5 V rectangular wave
Impedance	TTL-compatible

## Interface

Type	RS232 via 9-pin D type plug, configured as a DTE device. Two ports are provided allowing up to fifteen model 5105/5106 or compatible instruments to be controlled from a single computer port	
Parameters (fixed)	4800 baud, no parity, 8 data bits and 1 stop bit	
Addressing	Rear panel rotary switch assigns a unique address to each instrument	
Controls	Sensitivity, High and Low-Pass Filter settings, Dynamic Reserve, Reference Phase, Time Constant and Slope can all be set and read via RS232 command	
Auto Functions	Auto-Phase and Auto-Offset	
Data Transfer Rate	6 - 8 readings per second typical	
Outputs		
X and Y		Max count = $\pm 1200$ ( $\pm 1000 = \text{FS}$ )
Magnitude		Max count = 1200 (1000 = FS)
Signal Phase		Max count = $\pm 1800$ , corresponding to $\pm 180^\circ$
Ref Frequency		Response in millihertz

## Software & RS232 Cable

A full applications package for PC compatible computer providing access to all instrument controls and outputs, and supporting up to 16 units, is supplied with each instrument. In addition, a LabVIEW driver software suitable for versions 4.01 and later of LabVIEW is available by download from our website at [www.signalrecovery.com](http://www.signalrecovery.com)

The instrument is also compatible with the **SIGNAL RECOVERY** Acquire Lock-in Amplifier Applications software. A free demonstration version can be downloaded from the above website.

2 meter null-modem cable suitable for connecting the instrument to a 9-pin D-type RS232 plug on a PC computer also included.

## Power Requirements

+18 V DC unregulated @ 300 mA -18 V DC unregulated @ 80 mA  
 A separate power supply (model PS0108) suitable for 110 V 60 Hz or 230 V 50 Hz operation is supplied with each model 5105 and available as an optional extra for each model 5106 instrument

## Dimensions

### Model 5105

Width	8¼" (209 mm)
Depth	10½" (266 mm)
Height	3½" (85 mm)
Weight	5 lb (2.3 kg)

### Model 5106

#### Dimensions

Width	6½" (167 mm)
Depth	9¼" (233 mm)
Height	1½" (40 mm)

### B1 RS232 Connector Pinout

The **PORT 1** RS232 connector has the following pinout:

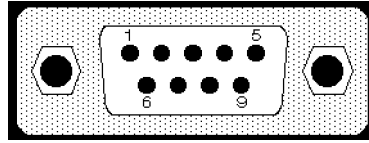

Figure B-1, RS232 PORT 1 Connector (Male)

Pin	Function	Description
2	Receive Data	The 5105/5106 receives data on this line
3	Transmit Data	The 5105/5106 transmits data on this line
5	Logic Ground	Data signals are referenced with respect to the voltage at this pin
7	Request to Send	This line is always asserted by the 5105/5106
8	Clear to Send	The model 5105/5106 does not respond to this line

All other pins are not connected

The **PORT 2** RS232 connector is suitable for connection to the **PORT 1** connector of a second model 5105 or 5106 using the RS232 cable supplied with the instrument, to construct a “daisy chain”.

### B2 Power Input Connector

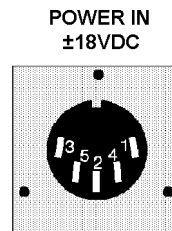

Figure B-2, Power Input Connector

The pin allocation of this connector is as follows:

Pin	Function
1	No Connection
2	Ground/Earth
3	No Connection
4	-18 V
5	+18 V

The mating plug is SWITCHCRAFT® type 05BL5M or equivalent

(**SIGNAL RECOVERY** part number 2102-0171).

# Demonstration Programs

## C.1 Simple Terminal Emulator

This is a short terminal emulator with minimal facilities, which will run on a PC-compatible computer in a Microsoft GWBASIC or QuickBASIC environment, or can be compiled with a suitable compiler.

```
10 'MINITERM 18-Dec-2000
20 CLS : PRINT "Lockin RS232 parameters must be set to 4800 baud, 8 data bits, 1 stop
   bit and no parity"
30 PRINT "Hit <ESC> key to exit"
40 OPEN "COM1:4800,N,8,1,CS,DS" FOR RANDOM AS #1
50 '.....
60 ON ERROR GOTO 180
70 '.....
100 WHILE (1)
110     B$ = INKEY$
120     IF B$ = CHR$(27) THEN CLOSE #1: ON ERROR GOTO 0: END
130     IF B$ <> "" THEN PRINT #1, B$;
140     LL% = LOC(1)
150     IF LL% > 0 THEN A$ = INPUT$(LL%, #1): PRINT A$;
160 WEND
170 '.....
180 PRINT "ERROR NO."; ERR: RESUME
```

## C.2 RS232 Control Program with Handshakes

RSCOM2.BAS is a user interface program which illustrates the principles of the echo handshake. The program will run on a PC-compatible computer either in a Microsoft GWBASIC or QuickBASIC environment, or in compiled form.

The subroutines in RSCOM2 are recommended for incorporation in the user's own programs.

```
10 'RSCOM2 18-Dec-2000
20 CLS : PRINT "Lockin RS232 parameters must be set to 4800 baud, 8 data bits, 1 stop
   bit, no parity"
30 OPEN "COM1:4800,N,8,1,CS,DS" FOR RANDOM AS #1
40 CR$ = CHR$(13) ' carriage return
50 '
60 '...main loop.....
70 WHILE 1 ' infinite loop
80     INPUT "command (00 to exit) "; B$ ' no commas are allowed in B$
90     IF B$ = "00" THEN END
100    B$ = B$ + CR$ ' append a carriage return
110    GOSUB 180 ' output the command B$
120    GOSUB 310: PRINT Z$; ' read and display response
```

```

130     IF A$ = "?" THEN GOSUB 410: GOSUB 470 ' if "?" prompt fetch STATUS%
140                                     ' and display message
150 WEND                                     ' return to start of loop
160 '
170 '
180 '...output the string B$.....
190 ON ERROR GOTO 510                       ' enable error trapping
200 IF LOC(1) > 0 THEN A$ = INPUT$(LOC(1), #1) ' clear input buffer
210 ON ERROR GOTO 0                         ' disable error trapping
220 FOR J1% = 1 TO LEN(B$)                 ' LEN(B$) is number of bytes
230     C$ = MID$(B$, J1%, 1): PRINT #1, C$; ' send byte
240     WHILE LOC(1) = 0: WEND              ' wait for byte in input buffer
250     A$ = INPUT$(1, #1)                  ' read input buffer
260     IF A$ <> C$ THEN PRINT "handshake error" ' input byte should be echo
270 NEXT J1%                                ' next byte to be sent or
280 RETURN                                  ' return if no more bytes
290 '
300 '
310 '....read response.....
320 A$ = "": Z$ = ""
330 WHILE (A$ <> "*" AND A$ <> "?")         ' read until prompt received
340     Z$ = Z$ + A$                         ' append next byte to string
350     WHILE LOC(1) = 0: WEND               ' wait for byte in input buffer
360     A$ = INPUT$(1, #1)                   ' read byte from buffer
370 WEND                                     ' next byte to be read
380 RETURN                                  ' return if it is a prompt
390 '
400 '
410 '....fetch status byte.....
420 B$ = "ST" + CR$                          ' "ST" is the status command
430 GOSUB 180                                ' output the command
440 GOSUB 310                                ' read response into Z$
450 STATUS% = VAL(Z$)                        ' convert to integer
460 RETURN
470 '....instrument error message.....
480 PRINT "Error prompt, status byte = "; STATUS% ' bits are defined in manual
490 PRINT
500 RETURN
510 '....I/O error routine.....
520 RESUME

```

# Cable Diagrams

## D.1 RS232 Cable Diagrams

Users who choose to use the RS232 interface to connect the model 5105 or 5106 lock-in amplifier to a standard serial port on a computer will need to use one of two types of cable. The only difference between them is the number of pins used on the connector which goes to the computer. One has 9 pins and the other 25; both are null-modem (also called modem eliminator) cables in that some of the pins are cross-connected.

Instruments are supplied with a cable suitable for a 9-pin computer port (figure D1) since this is the most common type. However, in the event that this is mislaid or if a cable for a 25-pin port is required then the users with reasonable practical skills can easily assemble the required cables from parts which are widely available through computer stores and electronics components suppliers. The required interconnections are given in figures D-1 and D-2.

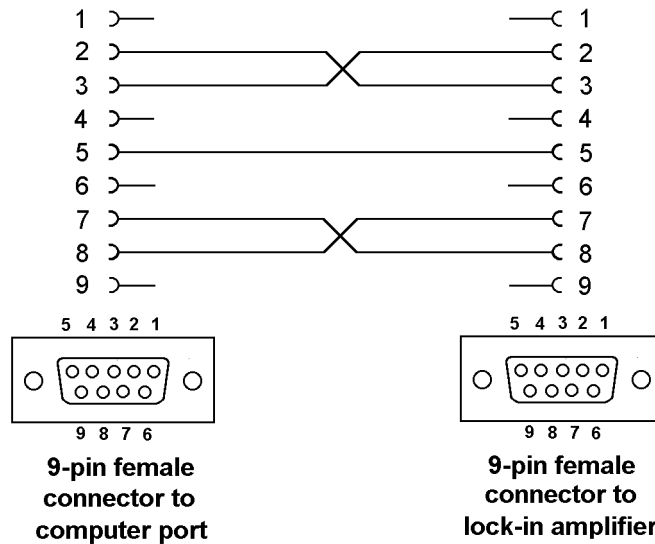

Figure D-1, Interconnecting RS232 Cable Wiring Diagram

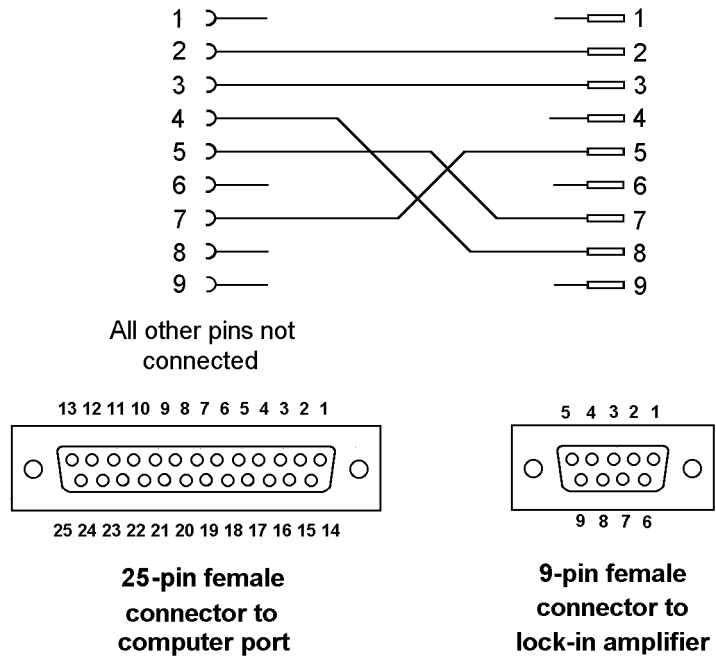

Figure D-2, Interconnecting RS232 Cable Wiring Diagram

# Alphabetical Listing of Commands

`\ n`                      Address command  
When the model 5105 or 5106 is daisy-chained with other compatible instruments this command will change which instrument is addressed. All daisy-chained instruments receive commands but only the currently addressed instrument will implement or respond to the commands. The exception is the `\ n` command. If `n` matches the address set from the rear panel switch the unit will switch into addressed mode. If `n` does not match this address instrument will switch into unaddressed mode. Note that the `\ n` command does not change the address of an instrument but which instrument is addressed.

*NOTE: All instruments must have a unique address.*

AQN                      Auto-Phase (auto quadrature null)  
The instrument adjusts the reference phase to maximize the X channel output and minimize the Y channel output signals.

AXO                      Auto-Offset  
This command turns on the X and Y channel output offsets, and assuming that there is sufficient range, are set to levels giving zero X and Y channel outputs. Any changes in the input signal then appear as changes about zero in the outputs.

CADDR                    Return current address  
The CADDR returns the setting of the RS232 address switch and hence the address of the currently selected unit.

CONFIG [n]              Configure error message status  
The value of `n` sets the error message status and the terminator sent with each transmission from the instrument to the computer according to the following table:

n	Error Message Status	Output Terminator Status
0	Error messages disabled	Append <CR><LF>
4	Error messages enabled	Append <CR><LF>
128	Error messages disabled	No terminator

Other values of `n` are invalid.

DD [n]                    Define delimiter control  
The value of `n`, which can be set to 13 or from 32 to 125, determines the ASCII value of the character sent by the lock-in amplifier to separate two numeric values in a two-value response, such as that generated by the XY (magnitude and phase) command. The default (power-up) setting is 32, corresponding to a space character.

DR [n]                    Dynamic Reserve control  
The value of `n` sets the dynamic reserve mode according to the following table:

- n Mode
- 0 High Stability
- 1 Normal
- 2 High Reserve

DRQMODE [n] Data request mode control

The value of parameter n sets or reads the data request mode status in accordance with the following table:

- n significance
- 0 Normal operation
- 1 Data Request Mode active

FRQ Reference frequency meter

The FRQ command causes the lock-in amplifier to respond with 0 if the reference channel is unlocked, or with the reference input frequency, expressed in millihertz, if it is locked.

HELP Display command list

The HELP command displays a list on an attached terminal of the commands that the instrument responds to. It is of most use when operating the unit from such a terminal and is not normally used when controlling it from a program.

HPF [n] Signal channel high-pass filter control

The HPF command sets the frequency of the low-pass signal channel filter mode according to the following table:

- n Selection
- 0 1 Hz
- 1 10 Hz
- 2 100 Hz
- 3 1 kHz

ID Identification

Causes the lock-in amplifier to respond with its model number, either 5105 or 5106.

LPF [n] Signal channel low-pass filter control

In standard units, which operate to 20 kHz, the LPF command sets the frequency of the low-pass signal channel filter mode according to the following table:

- n Selection
- 0 50 Hz
- 1 500 Hz
- 2 5 kHz
- 3 50 kHz

However, units supplied calibrated to operate at spot frequencies in the range 20 kHz to 100 kHz have modified filter settings, as follows:

n	Selection
0	220 Hz
1	2.2 kHz
2	22 kHz
3	220 kHz

**MAG** Magnitude

The MAG command causes the lock-in amplifier to respond with the magnitude value in the range 0 to +1200, full-scale being +1200.

**N** Report overload byte

Causes the lock-in amplifier to respond with the overload byte, an integer between 0 and 255, which is the decimal equivalent of a binary number with the following bit-significance:

Bit 0	not used
Bit 1	not used
Bit 2	not used
Bit 3	CH1 (X-channel) output overload ( $> \pm 120\%$ FS)
Bit 4	CH2 (Y-channel) output overload ( $> \pm 120\%$ FS)
Bit 5	Phase Sensitive Detector(s) overload
Bit 6	Signal Channel Overload
Bit 7	Reference unlock

**OFEN [n]** Output offset status control

The value of n sets the offset status of both the X and Y channel output offsets according to the following table:

n	Selection
0	Disables offsets
1	Enables offsets

**OUTLIST  $n_1 n_2$**  Output values at regular intervals

The OUTLIST command generates a continuous stream of output readings, equivalent to the XY command response if  $n_1 = 0$  or the MAG command response if  $n_1 = 1$ . Readings are sent at the rate of one every  $t$  seconds, where  $t = n_2$  and lies in the range 1 to 100 seconds. If  $n_2$  is set equal to 0 then readings are sent as rapidly as possible. Sending any character to the instrument stops the output.

This command is most useful when the instrument is connected to a simple RS232 terminal.

**OUTPLOT  $n_1 n_2$**  Output a "plot" of values at regular intervals

The OUTPLOT command is the same as the OUTLIST command except that the response on an RS232 terminal using a fixed pitch font on an 80-character wide screen is a graphical representation of the numbers generated. Sending any character to the instrument stops the output.

This command is most useful when the instrument is connected to a simple RS232 terminal.

P [n<sub>1</sub> n<sub>2</sub>]                      Reference phase control

The P command sets the reference phase according to the following table:

n <sub>1</sub>	Quadrant	Phase Range
0	1	0° to 90°
1	2	90° to 180°
2	3	180° to 270°
3	4	270° to 360°

n<sub>2</sub> is in units of 0.1° and hence takes values in the range 0 to 1000 corresponding to phase shifts of 0 to 100°

For example, to set the reference phase to 45° send the command P 0 450

PHA                                      Signal phase

The PHA command causes the lock-in amplifier to respond with the signal phase in centidegrees, in the range ±1800 corresponding to ±180.0°

SEN [n]                                Full-scale sensitivity control

The value of n sets the full-scale sensitivity according to the following table

n	full-scale sensitivity
0	10 μV
1	31.6 μV
2	100 μV
3	316 μV
4	1 mV
5	3.16 mV
6	10 mV
7	31.6 mV
8	100 mV
9	316 mV
10	1 V

**NOTE: If the Sensitivity setting is 10 μV, 31.6 μV or 100 μV (0 ≤ n ≤ 2) then setting the Time Constant to 10 ms or shorter will cause the Sensitivity setting to change to 316 μV (n = 3)**

ST                                        Report status byte

Causes the lock-in amplifier to respond with the status byte, an integer between 0 and 31, which is the decimal equivalent of a binary number with the following bit-significance:

Bit 0	Command complete
Bit 1	Invalid command
Bit 2	Command parameter error
Bit 3	Reference unlock
Bit 4	Overload

- TC [n]  
 XTC [n]                      Output filters time constant control  
 The value of n sets the time constant of the outputs according to the following table:
- | n | Time constant |
|---|---------------|
| 0 | 300 $\mu$ s   |
| 1 | 1 ms          |
| 2 | 3 ms          |
| 3 | 10 ms         |
| 4 | 30 ms         |
| 5 | 100 ms        |
| 6 | 300 ms        |
| 7 | 1 s           |
| 8 | 3 s           |
| 9 | 10 s          |
- The time constants and outputs available depend on the full-scale sensitivity setting, as follows:
- Time Constant = 300  $\mu$ s to 10 ms**  
 Analog and Digital outputs but only with Sensitivity settings in range of 300  $\mu$ V to 1 V. This is known as the FAST mode.
- Time Constant = 30 m to 1 s**  
 Analog and Digital outputs at all Sensitivity settings.
- Time Constant = 3 s and 10 s**  
 Digital outputs only at all Sensitivity settings.
- VER                      Report firmware version  
 Causes the lock-in amplifier to respond with the firmware version number. This gives a two-line response which the controlling program must be able to accept.
- X                      X channel output  
 The X command causes the lock-in amplifier to respond with the X demodulator output in the range  $\pm 1200$ , full-scale being  $\pm 1000$ .
- XDB [n]                      Output low-pass filter slope (roll-off) control  
 The value of n sets the slope of the output filters according to the following table:
- | n | Slope        |
|---|--------------|
| 0 | 6 dB/octave  |
| 1 | 12 dB/octave |
- XOF [n<sub>1</sub> [n<sub>2</sub>]]                      X channel output offset control  
 The value of n<sub>1</sub> sets the status of the X channel output offset facility according to the following table:
- | n <sub>1</sub> | Selection                             |
|----------------|---------------------------------------|
| 0              | Disables X offset                     |
| 1              | Enables X offset facility if OFEN = 1 |

The range of  $n_2$  is  $\pm 200$  corresponding to  $\pm 20\%$  full-scale.

**NOTE: Offsets apply only to the digital outputs and not to the CH1 or CH2 analog outputs.**

XY X, Y channel outputs

The XY command causes the lock-in amplifier to respond with the X and Y demodulator outputs, separated by the character defined by the DD command, in the range  $\pm 1200$ , full-scale being  $\pm 1000$ .

YOF [ $n_1$  [ $n_2$ ]] Y channel output offset control

The value of  $n_1$  sets the status of the Y channel output offset facility according to the following table:

$n_1$  Selection

0 Disables Y offset facility

1 Enables Y offset facility if OFEN = 1

The range of  $n_2$  is  $\pm 200$  corresponding to  $\pm 20\%$  full-scale.

**NOTE: Offsets apply only to the digital outputs and not to the CH1 or CH2 analog outputs.**

- \n command 6-10, E-1
- 5105Acquire
  - Editing instrument descriptions 5-3
  - filters tab 5-6
  - getting started 5-1
  - input tab 5-5
  - installation 5-1
  - Instrument connections dialog 5-1
  - main display 5-4
  - output tab 5-7
  - overview 5-1
  - reference tab 5-6
  - Searching for Instruments dialog 5-2
- Accuracy 3-16
- Analog to digital converter (ADC) 3-12
- AQN command 6-6, E-1
- Auto functions
  - Auto-Offset 3-15
  - Auto-Phase 3-14
  - introduction 3-14
- Auxiliary RS232 interface 6-2
- AXO command 6-8, E-1
- Block diagram 3-1
- CADDR command 6-11, E-1
- CH1 output 3-12
- CH2 output 3-12
- Commands
  - compound 6-4
  - descriptions of 6-5
  - for computer interfaces 6-10
  - for instrument identification 6-11
  - for instrument outputs 6-8
  - for reference channel 6-6
  - for signal channel inputs 6-5
  - for signal channel output amplifiers 6-7
  - for signal channel output filters 6-7
  - format 6-4
- Common mode rejection ratio (CMRR) 3-1
- Computer control, sample programs 6-12
- Computer operation, introduction 6-1
- CONFIG [n] command 6-10, E-1
- Converting command responses to voltages 6-12
- DD [n] command 6-4, 6-11, E-1
- Delimiters 6-4
- Demodulators
  - overview 3-7
  - sinewave mode 3-8
  - squarewave mode 3-7
- Direct mode 6-1
- DR [n] command 6-7, E-1
- DRQ (Data Request Mode) 6-3
- DRQMODE [n] command 6-11, E-2
- Dynamic reserve
  - demodulator reserve 3-11
  - filter reserve 3-11
  - overview 3-10
- External Power
  - Model 5105 2-1
  - Model 5106 2-3
- FRQ command 6-6, E-2
- Fuses
  - line 2-2
  - ratings 2-2
- Handshaking and echos 6-2
- HELP command 6-11, E-2
- HPF [n] command 6-6, E-2
- ID command 6-11, E-2
- Initial checks 2-3
- Input
  - connector selection 4-1, 4-4
  - high-pass filter 3-4
  - low-pass filter 3-3
  - mode selection 3-2
  - signal channel filters 3-3
- Inspection 2-1
- Key specifications 1-3
- Line voltage selection 2-2
- Lock acquisition time 3-5
- LPF [n] command 6-5, E-2
- MAG command 6-8, E-3
- Microprocessor - general 3-13
- Microsoft Windows HyperTerminal program 6-1
- Model 5105 Front Panel
  - CH1 connector 4-1
  - CH2 connector 4-1
  - layout 4-1
  - power LED 4-1
  - REF IN connector 4-1
  - SIGNAL connector 4-1
- Model 5105 Rear Panel
  - DEVICE ADDR/BAUD switch 4-2
  - layout 4-2
  - PORT 1 RS232 connector 4-2
  - PORT 2 RS232 connector 4-2
  - power input socket 4-2
  - REF. MON connector 4-3

- SIG. MON connector 4-3
- Model 5106 PCB assembly
  - CH1 connecting point 4-5
  - CH2 connecting point 4-5
  - connections overview 4-3
  - DEVICE ADDR/BAUD switch 4-6
  - PORT 1 RS232 Connector 4-5
  - PORT 2 RS232 Connector 4-6
  - POWER input socket 4-5
  - power LED 4-5
  - REF INPUT connecting point 4-4
  - REF MON connector 4-6
  - SIG MON connector 4-6
  - SIGNAL connecting point 4-4
- N command 6-5, 6-11, E-3
- Null modem 6-1
- OFEN [n] command 6-7, E-3
- Operating environment 2-1
- OUTLIST  $n_1 n_2$  command 6-9, E-3
- OUTPLOT  $n_1 n_2$  command 6-9, E-3
- Output
  - output filters 3-8
  - output offset 3-10
  - stability 3-10
- Overload
  - detection 3-12
  - input overload 3-12
  - output overload 3-12
  - overload byte 6-4
- P [ $n_1 n_2$ ] command 6-6, E-3
- PHA command 6-9, E-4
- Power-up defaults 3-16
- Programming examples 6-12
- Prompt character 6-4
- Rack mounting 2-1
- REF MON connector 3-6
- Reference channel
  - configuring frequency range 3-6
  - configuring input mode 3-5
  - overview 3-4
  - phase shifter 3-5
- RS232 interface
  - address 6-2
  - connector pinout B-1
  - general features 6-1
  - input terminator 6-3
  - output terminator 6-3
- SEN [n] command 6-5, E-4
- Signal channel inputs 3-1
- Signal Monitor output 3-4
- Signal phase 3-13
- ST command 6-4, 6-11, E-4
- Static damage and warranty 2-1, 2-5
- Status byte 6-4
- TC command 6-7, E-5
- Terminal emulator 6-1
- Terminal mode 6-1
- Terminators 6-3
- Vector magnitude 3-13
- VER command 6-12, E-5
- What is a lock-in amplifier? 1-2
- X command 6-8, E-5
- XDB [n] command 6-7, E-5
- XOF [ $n_1 [n_2]$ ] command 6-8, E-5
- XTC command 6-7, E-5
- XY command 6-8, E-6
- YOF [ $n_1 [n_2]$ ] command 6-8, E-6

# WARRANTY

**SIGNAL RECOVERY**, a part of AMETEK Advanced Measurement Technology, Inc, warrants each instrument of its own manufacture to be free of defects in material and workmanship for a period of ONE year from the date of delivery to the original purchaser. Obligations under this Warranty shall be limited to replacing, repairing or giving credit for the purchase, at our option, of any instruments returned, shipment prepaid, to our Service Department for that purpose, provided prior authorization for such return has been given by an authorized representative of AMETEK Advanced Measurement Technology, Inc.

This Warranty shall not apply to any instrument, which our inspection shall disclose to our satisfaction, to have become defective or unusable due to abuse, mishandling, misuse, accident, alteration, negligence, improper installation, or other causes beyond our control. This Warranty shall not apply to any instrument or component not manufactured by AMETEK Advanced Measurement Technology, Inc. When products manufactured by others are included AMETEK Advanced Measurement Technology, Inc equipment, the original manufacturers Warranty is extended to AMETEK Advanced Measurement Technology, Inc customers. AMETEK Advanced Measurement Technology, Inc reserves the right to make changes in design at any time without incurring any obligation to install same on units previously purchased.

THERE ARE NO WARRANTIES WHICH EXTEND BEYOND THE DESCRIPTION ON THE FACE HEREOF. THIS WARRANTY IS IN LIEU OF, AND EXCLUDES ANY AND ALL OTHER WARRANTIES OR REPRESENTATIONS, EXPRESSED, IMPLIED OR STATUTORY, INCLUDING MERCHANTABILITY AND FITNESS FOR A PARTICULAR PURPOSE, AS WELL AS ANY AND ALL OTHER OBLIGATIONS OR LIABILITIES OF AMETEK ADVANCED MEASUREMENT TECHNOLOGY, INC, INCLUDING, BUT NOT LIMITED TO, SPECIAL OR CONSEQUENTIAL DAMAGES. NO PERSON, FIRM OR CORPORATION IS AUTHORIZED TO ASSUME FOR AMETEK ADVANCED MEASUREMENT TECHNOLOGY, INC ANY ADDITIONAL OBLIGATION OR LIABILITY NOT EXPRESSLY PROVIDED FOR HEREIN EXCEPT IN WRITING DULY EXECUTED BY AN OFFICER OF AMETEK ADVANCED MEASUREMENT TECHNOLOGY, INC.

## SHOULD YOUR EQUIPMENT REQUIRE SERVICE

- A. Contact your local AMETEK SIGNAL RECOVERY office, agent, representative or distributor to discuss the problem. In many cases it may be possible to expedite servicing by localizing the problem to a particular unit or cable.
- B. We will need the following information, a copy of which should also be attached to any equipment which is returned for service.
- |   |   |
|---|---|
| 1. Model number and serial number of instrument       | 6. Symptoms (in detail, including control settings)   |
| 2. Your name (instrument user)                        | 7. Your purchase order number for repair charges (does not apply to repairs in warranty)                            |
| 3. Your address                                       | 8. Shipping instructions (if you wish to authorize shipment by any method other than normal surface transportation) |
| 4. Address to which the instrument should be returned |   |
| 5. Your telephone number and extension                |   |
- C. If you experience any difficulties in obtaining service please contact:

**SIGNAL RECOVERY** Service

AMETEK Advanced Measurement Technology, Inc  
801 South Illinois Avenue  
Oak Ridge  
TN 37831-2011, USA

Phone: +1 865 482 4411  
Fax: +1 865 481 2410  
E-mail: [info@signalrecovery.com](mailto:info@signalrecovery.com)

or

**SIGNAL RECOVERY** Service

AMETEK Advanced Measurement Technology  
Spectrum House, 1 Fishponds Close  
Wokingham,  
RG41 2TZ, UNITED KINGDOM

Phone: +44 (0)118 936 1210  
Fax: +44 (0)118 936 1211  
E-mail: [info@signalrecovery.com](mailto:info@signalrecovery.com)